

TOOL HOLDERS

HYDRAULIC CHUCK

SHRINK FIT HOLDER

MILLING CHUCK

SK SLIM CHUCK

ER COLLET CHUCK

NC DRILL CHUCK

MORSE TAPER ARBOR

TAPPING ER CHUCK

TAP CHUCK

END MILL HOLDER & SIDE LOCK ARBOR

FACE MILL SYSTEM

FACE MILL SYSTEM

SHELL MILL ARBOR & COMBI SMA

BORING SYSTEM

TOOL HOLDERS INDEX

HYDRAULIC CHUCK

 MAS403-BT page : 1064~1067	 DIN69893-HSK page : 1068~1070	 DIN69871-SK page : 1071~1073	 MAS403-BT (HMC) page : 1074
 DIN69893-HSK (HMC) page : 1075	 DIN69871-SK (HMC) page : 1076	 DIN228-MTB (For Grinder) page : 1077	 COLLET page : 1078





SHRINK FIT HOLDER

 MAS403-BT page : 1079~1080	 DIN69893-HSK page : 1081~1083	 DIN69871-SK page : 1084~1085	 EXTENSION page : 1086~1087
--	---	--	--

MILLING CHUCK

 MAS403-BT page : 1088~1089	 DIN69893-HSK page : 1090~1091	 DIN69871-SK page : 1092~1093	 DIN228-MTA page : 1094
 R8 page : 1095	 STANDARD SET page : 1096	 Q.C SET page : 1097	 COLLET & SPANNER page : 1098

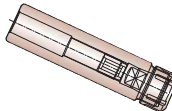
SK SLIM CHUCK

 MAS403-BT page : 1099~1100	 DIN69893-HSK page : 1101	 K page : 1102	 COLLET & NUT page : 1103~1104
--	--	---	---

ER COLLET CHUCK

 MAS403-BT page : 1106~1107	 DIN69893-HSK page : 1108~1109	 DIN69871-SK page : 1110~1111	 MAS403-BT page : 1112
 DIN228-MTA page : 1113	 DIN228-MTB page : 1114	 K page : 1115~1116	 NC page : 1117
 ER COLLET-UF page : 1118~1119	 ER COLLET for TAP page : 1120	 ER SPANNER / WRENCH page : 1121	

NC DRILL CHUCK

 MAS403-BT page : 1122	 K page : 1123	 JACOBS TAPER ADAPTER page : 1124
---	---	--





MORSE TAPER ARBOR

 MAS403-BT page : 1125~1126	 ANSI B5.18-NT page : 1127	 DIN69893-HSK page : 1128	 DIN69871-SK page : 1129
--	---	--	---

TAPPING ER CHUCK

 MAS403-BT page : 1130	 DIN69893-HSK page : 1131	 DIN69871-SK page : 1132
---	--	--

TAP CHUCK

 MAS403-BT page : 1133	 K page : 1134	 DIN69893-HSK page : 1135	 DIN69871-SK page : 1136
 DIN228-MTA page : 1136	 TAP ADAPTER page : 1137		

END MILL HOLDER & SIDE LOCK ARBOR

 DIN69871-SK page : 1138~1140	 DIN69893-HSK page : 1141~1142	 MAS403-BT(EMH) page : 1143	 MAS403-BT(SLA) page : 1144 (SLB) page : 1145
--	---	---	--

FACE MILL SYSTEM

 MAS403-BT (FMA) page : 1146	 DIN2080-NT (FMA) page : 1147	 DIN228-MTA (FMA) page : 1147	 MAS403-BT (FMB) page : 1148
 MAS403-BT (FMC) page : 1149	 DIN69893-HSK page : 1150		

SHELL MILL ARBOR & COMBI SMA

 MAS403-BT page : 1151	 DIN69893-HSK page : 1152	 DIN69871-SK page : 1153	 MAS403-BT (SCA) page : 1155
 DIN69893-HSK (CMA) page : 1156	 DIN69871-SK (CMA) page : 1157	 MAS403-BT (CMA) page : 1158	 DIN2080-ISO (CMA) page : 1159

BORING SYSTEM

 MAS403-BT (TBH) page : 1161	 DIN69871-SK (TBH) page : 1162	 MAS403-BT (SAS) page : 1163	 DIN69871-SK (SAS) page : 1164
 MAS403-BT (TBH) page : 1167	 DIN69871-SK (TBH) page : 1168	 MAS403-BT (FBH) page : 1169	 DIN69871-SK (FBH) page : 1170
 MAS403-BT (SAS) page : 1171 DIN69871-SK (page : 1171)	 MAS403-BT (BCA) page : 1173~1174	 ST page : 1175	 MAS403-BT (BSA) page : 1179 (BSB) page : 1180

HYDRAULIC CHUCK (Radial tool length pre-setting type) HYDRAULIK SPANNFUTTER (Radiale Werkzeuglängen Voreinstellung)

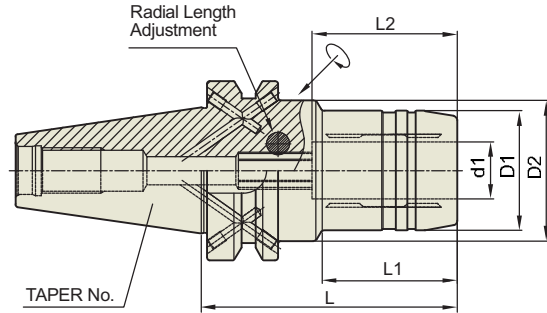
MAS403-BT FORM AD/B

MAS403 -BT	Taper Accuracy AT3	G Value 2.5	RPM 20,000	Coolant System AD/B
---------------	--------------------------	----------------	---------------	---------------------------

TAPER No.	CODE No.	d1	D1	D2	L	L1	L 2	Weight (kg)
30	BT30AD/B-HCR12-85	12	32	44.5	85	40	37	0.90
	BT30AD/B-HCR20-85	20	44	44	85	-	42	1.00
40	BT40AD/B-HCR12-90	12	32	44.5	90	44.5	37	1.50
	BT40AD/B-HCR20-90	20	42	49.5	90	47.5	42	1.60
	BT40AD/B-HCR32-105	32	60	60	105	-	55	2.20
50	BT50AD/B-HCR12-95	12	32	44.5	95	34	37	3.90
	BT50AD/B-HCR20-95	20	42	44.5	95	34	42	4.00
	BT50AD/B-HCR32-115	32	60	60	115	-	55	4.10

- ▶ In case of BT50, balancing grade shall be guaranteed up to G2.5/15,000rpm.
- ▶ Higher balancing grade product up to G2.5/40,000(G6.3/100,000rpm) could be supplied by customer's request.

HYDRAULIC CHUCK (SHORT & HEAVY) HYDRAULIK SPANNFUTTER (KURZ und SCHWER)

 TOOL
HOLDERS

MAS403-BT FORM AD/B

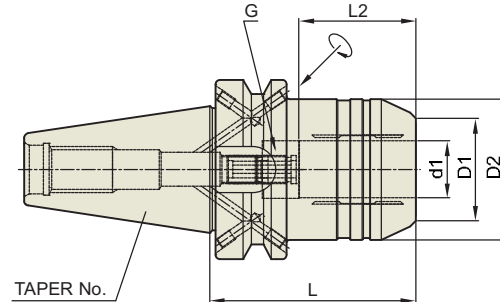

MAS403 -BT	Taper Accuracy AT3	G Value 2.5	RPM 20,000	Coolant System AD/B
---------------	--------------------------	----------------	---------------	---------------------------

TAPER No.	CODE No.	d1	D1	D2	L	L 2	G	Weight (kg)
30	BT30AD/B-HC20S-85	20	41	44	85	42	M10×1.0	0.93
40	BT40AD/B-HC20S-72.5	20	37	49.5	72.5	42	M16×1.0	1.40
50	BT50AD/B-HC20S-90	20	37	49.5	90	42	M16×1.0	3.85
	BT50AD/B-HC32S-90	32	55	72	90	55	M16×1.0	4.53

▶ In case of BT50, balancing grade shall be guaranteed up to G2.5/15,000rpm.

▶ Higher balancing grade product up to G2.5/40,000(G6.3/100,000rpm) could be supplied by customer's request.

HYDRAULIC CHUCK COLLET (REDUCTION SLEEVE)

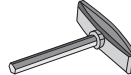
HK COLLET	CODE No.	T-WRENCH	CODE No.
	HK12	∅3 ~ ∅8	
	HK20	∅3 ~ ∅16	
	HK32	∅3 ~ ∅25	
			T-4 T-5

HYDRAULIC CHUCK (SLIM) HYDRAULIK SPANNFUTTER (SCHLANK)

MAS403-BT FORM AD/B

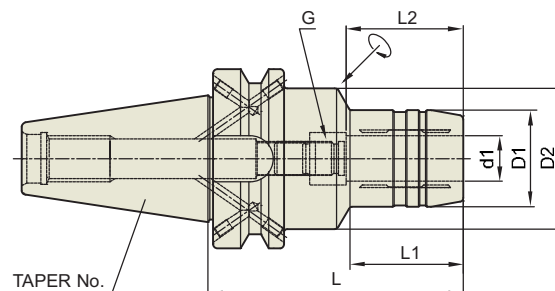

MAS403 -BT	Taper Accuracy AT3	G Value 2.5	RPM 20,000	Coolant System AD/B
---------------	--------------------------	----------------	---------------	---------------------------

TAPER No.	CODE No.	d1	D1	D2	L	L1	L2	G	Weight (kg)
30	BT30AD/B-HC6-70	6	26	44.5	70	29.5	27	M5×0.8	0.65
	BT30AD/B-HC8-70	8	28	44.5	70	30	27	M6×1.0	0.65
	BT30AD/B-HC10-75	10	30	44.5	75	31	32	M8×1.0	0.73
	BT30AD/B-HC12-85	12	32	44.5	85	40	37	M10×1.0	0.80
	BT30AD/B-HC14-85	14	34	44.5	85	40	37	M10×1.0	0.80
	BT30AD/B-HC16-90	16	38	44.5	90	46	42	M12×1.0	0.90
	BT30AD/B-HC18-90	18	40	44.5	90	46	42	M12×1.0	0.90
	BT30AD/B-HC20-90	20	42	44.5	90	48	42	M16×1.0	0.90
40	BT40AD/B-HC6-90	6	26	49.5	90	30	27	M5×0.8	1.30
	BT40AD/B-HC8-90	8	28	49.5	90	30	27	M6×1.0	1.30
	BT40AD/B-HC10-90	10	30	49.5	90	32	32	M8×1.0	1.35
	BT40AD/B-HC12-90	12	32	49.5	90	35	37	M10×1.0	1.35
	BT40AD/B-HC14-90	14	34	49.5	90	35	37	M10×1.0	1.35
	BT40AD/B-HC16-90	16	38	49.5	90	40	42	M12×1.0	1.40
	BT40AD/B-HC18-90	18	40	49.5	90	40	42	M12×1.0	1.45
	BT40AD/B-HC20-90	20	42	49.5	90	40	42	M16×1.0	1.50
		BT40AD/B-HC25-100	25	50	60	100	45	48	M16×1.0
	BT40AD/B-HC32-105	32	60	60	105	50	55	M16×1.0	2.10

► Higher balancing grade product up to G2.5/40,000(G6.3/100,000rpm) could be supplied by customer's request.

HYDRAULIC CHUCK (SLIM) HYDRAULIK SPANNFUTTER (SCHLANK)

 TOOL
HOLDERS

MAS403-BT FORM AD/B

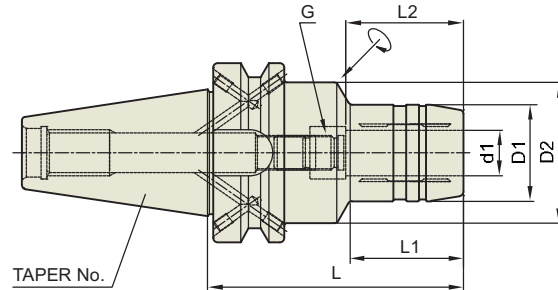

MAS403 -BT	Taper Accuracy AT3	G Value 2.5	RPM 15,000	Coolant System AD/B
---------------	--------------------------	----------------	---------------	---------------------------

TAPER No.	CODE No.	d1	D1	D2	L	L1	L2	G	Weight (kg)
50	BT50AD/B-HC6-90	6	26	44.5	90	43	27	M5×0.8	3.75
	BT50AD/B-HC6-120	6	26	44.5	120	43	27	M5×0.8	4.10
	BT50AD/B-HC6-150	6	26	44.5	150	43	27	M5×0.8	4.70
	BT50AD/B-HC8-90	8	28	44.5	90	44.5	27	M6×1.0	3.75
	BT50AD/B-HC8-120	8	28	44.5	120	44.5	27	M6×1.0	4.10
	BT50AD/B-HC8-150	8	28	44.5	150	44.5	27	M6×1.0	4.10
	BT50AD/B-HC10-90	10	30	44.5	90	44.5	32	M8×1.0	3.90
	BT50AD/B-HC10-120	10	30	44.5	120	44.5	32	M8×1.0	4.30
	BT50AD/B-HC10-150	10	30	44.5	150	44.5	32	M8×1.0	4.90
	BT50AD/B-HC12-90	12	32	44.5	90	44.5	37	M10×1.0	3.90
	BT50AD/B-HC12-120	12	32	44.5	120	44.5	37	M10×1.0	4.30
	BT50AD/B-HC12-150	12	32	44.5	150	44.5	37	M10×1.0	4.90
	BT50AD/B-HC14-90	14	34	44.5	90	44.5	37	M10×1.0	3.90
	BT50AD/B-HC14-120	14	34	44.5	120	44.5	37	M10×1.0	4.30
	BT50AD/B-HC14-150	14	34	44.5	150	44.5	37	M10×1.0	4.90
	BT50AD/B-HC16-90	16	38	44.5	90	44.5	42	M12×1.0	4.00
	BT50AD/B-HC16-120	16	38	44.5	120	44.5	42	M12×1.0	4.40
	BT50AD/B-HC16-150	16	38	44.5	150	44.5	42	M12×1.0	5.00
	BT50AD/B-HC18-90	18	40	44.5	90	44.5	42	M12×1.0	4.00
	BT50AD/B-HC18-120	18	40	44.5	120	44.5	42	M12×1.0	4.40
BT50AD/B-HC18-150	18	40	44.5	150	44.5	42	M12×1.0	5.00	
BT50AD/B-HC20-90	20	42	44.5	90	44.5	42	M16×1.0	4.00	
BT50AD/B-HC20-120	20	42	44.5	120	44.5	42	M16×1.0	4.40	
BT50AD/B-HC20-150	20	42	44.5	150	44.5	42	M16×1.0	5.00	
BT50AD/B-HC25-105	25	50	60	105	47.5	42	M16×1.0	4.40	
BT50AD/B-HC25-150	25	50	60	150	47.5	42	M16×1.0	5.60	
BT50AD/B-HC32-115	32	60	60	115	-	42	M16×1.0	4.70	
BT50AD/B-HC32-150	32	60	60	150	-	42	M16×1.0	6.00	

► In case of Hydraulic Chuck with $\varnothing 12$, $\varnothing 20$ and $\varnothing 32$ ID, various cutting tools with different dia. can be used together with Hydraulic Chuck collet(reduction sleeve).

HYDRAULIC CHUCK (Radial tool length pre-setting type) HYDRAULIK SPANNFUTTER (Radiale Werkzeuglängen Voreinstellung)

DIN69893-HSK FORM A

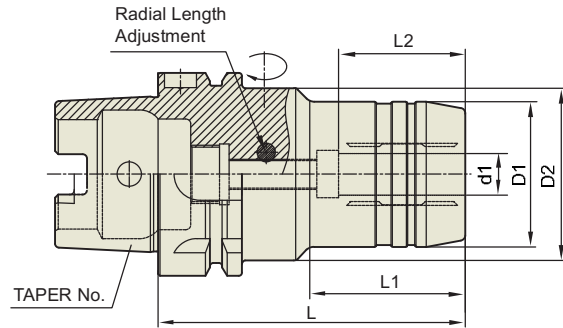

DIN69893 - HSK	Taper Accuracy AT3	G Value 2.5	RPM 20,000	Coolant System
-------------------	--------------------------	----------------	---------------	-------------------

TAPER No.	CODE No.	d1	D1	D2	L	L1	L2	Weight (kg)
40A	HSK40A-HCR6-80	6	26	34	80	36	27	0.55
	HSK40A-HCR8-80	8	28	34	80	36	27	0.55
	HSK40A-HCR10-85	10	30	34	85	43	32	0.65
	HSK40A-HCR12-90	12	32	34	90	48	37	0.70
50A	HSK50A-HCR6-80	6	26	50	80	35	27	0.70
	HSK50A-HCR8-80	8	28	50	80	35	27	0.70
	HSK50A-HCR10-85	10	30	50	85	38	32	0.73
	HSK50A-HCR12-90	12	32	50	90	40	37	0.80
	HSK50A-HCR14-90	14	34	50	90	40	37	0.80
	HSK50A-HCR16-95	16	38	53	95	34	42	1.00
	HSK50A-HCR18-95	18	40	57	95	34	42	1.00
	HSK50A-HCR20-100	20	42	60	100	34	42	1.10
63A	HSK63A-HCR6-80	6	26	50	80	33	27	0.96
	HSK63A-HCR8-80	8	28	50	80	33	27	0.98
	HSK63A-HCR10-85	10	30	50	85	38	32	1.04
	HSK63A-HCR12-90	12	32	50	90	40	37	1.06
	HSK63A-HCR14-90	14	34	50	90	46	37	1.08
	HSK63A-HCR16-95	16	38	50	95	51	42	1.18
	HSK63A-HCR18-95	18	40	50	95	52	42	1.20
	HSK63A-HCR20-100	20	42	50	100	51	42	1.22
	HSK63A-HCR25-120	25	57	63	120	54.5	48	2.20
HSK63A-HCR32-125	32	64	75	125	57.5	55	2.60	
100A	HSK100A-HCR6-85	6	26	63	85	33	27	3.60
	HSK100A-HCR8-85	8	28	63	85	33	27	3.60
	HSK100A-HCR10-90	10	30	63	90	36	32	3.80
	HSK100A-HCR12-95	12	32	63	95	40	37	3.80
	HSK100A-HCR14-95	14	34	63	95	41	37	3.80
	HSK100A-HCR16-100	16	38	63	100	46	42	3.90
	HSK100A-HCR18-100	18	40	63	100	46	42	3.90
	HSK100A-HCR20-105	20	42	75	105	51	42	4.20
	HSK100A-HCR25-115	25	57	75	115	55.5	48	4.40
HSK100A-HCR32-120	32	64	75	120	63.5	55	4.60	

▶ In case of HSK100A, balancing grade shall be guaranteed up to G2.5/15,000rpm.

▶ Higher balancing grade product up to G2.5/40,000 (G6.3/100,000rpm) could be supplied by customer's request.

HYDRAULIC CHUCK HYDRAULIK SPANNFUTTER

TOOL
HOLDERS

DIN69893-HSK FORM A

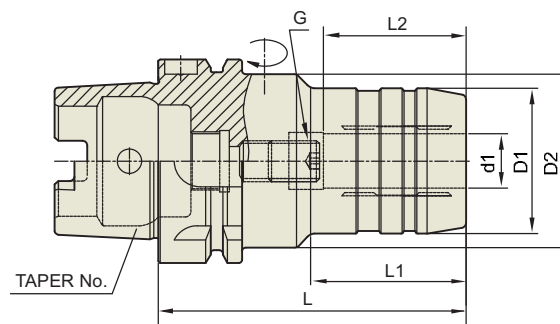

DIN69893 - HSK	Taper Accuracy AT3	G Value 2.5	RPM 20,000	Coolant System
-------------------	--------------------------	----------------	---------------	-------------------

TAPER No.	CODE No.	d1	D1	D2	L	L1	L2	G	Weight (kg)
40A	HSK40A-HC6-70	6	26	34	70	36	27	M5×0.8	0.50
	HSK40A-HC8-70	8	28	34	70	36	27	M6×1.0	0.50
	HSK40A-HC10-75	10	30	34	75	42	32	M6×1.0	0.60
	HSK40A-HC12-80	12	32	34	80	48	37	M6×1.0	0.65
50A	HSK50A-HC6-70	6	26	50	70	28	27	M5×0.8	0.65
	HSK50A-HC8-70	8	28	50	70	28	27	M6×1.0	0.65
	HSK50A-HC10-75	10	30	50	75	34	32	M8×1.0	0.70
	HSK50A-HC12-85	12	32	50	85	44	37	M10×1.0	0.75
	HSK50A-HC14-85	14	34	50	85	44	37	M10×1.0	0.75
	HSK50A-HC16-90	16	38	53	90	30	42	M12×1.0	0.90
	HSK50A-HC18-90	18	40	57	90	30	42	M12×1.0	0.90
HSK50A-HC20-90	20	42	60	90	34	42	M16×1.0	1.00	
63A	HSK63A-HC6-70	6	26	50	70	24	27	M5×0.8	0.53
	HSK63A-HC8-70	8	28	50	70	24	27	M6×1.0	0.55
	HSK63A-HC10-80	10	30	50	80	35	32	M8×1.0	1.00
	HSK63A-HC12-85	12	32	50	85	40	37	M10×1.0	1.03
	HSK63A-HC14-85	14	34	50	85	40	37	M10×1.0	1.05
	HSK63A-HC16-90	16	38	50	90	46	42	M12×1.0	1.15
	HSK63A-HC18-90	18	40	50	90	46	42	M12×1.0	1.15
	HSK63A-HC20-90	20	42	50	90	48	42	M16×1.0	1.20
	HSK63A-HC25-120	25	57	63	120	59	48	M16×1.0	2.20
HSK63A-HC32-125	32	64	75	125	63	55	M16×1.0	2.40	

► Higher balancing grade product up to G2.5/40,000(G6.3/100,000rpm) could be supplied by customer's request.

HYDRAULIC CHUCK HYDRAULIK SPANNFUTTER

DIN69893-HSK FORM A

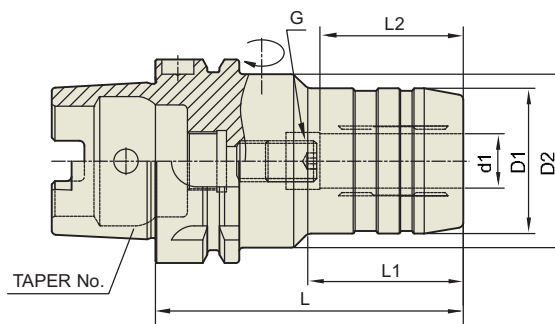

DIN69893 - HSK	Taper Accuracy AT3	G Value 2.5	RPM 15,000	Coolant System
-------------------	--------------------------	----------------	---------------	-------------------

TAPER No.	CODE No.	d1	D1	D2	L	L1	L 2	G	Weight (kg)
100A	HSK100A-HC6-75	6	26	50	75	24	27	M5×0.8	3.20
	HSK100A-HC8-75	8	28	50	75	24	27	M6×1.0	3.20
	HSK100A-HC10-90	10	30	50	90	35	32	M8×1.0	3.40
	HSK100A-HC12-95	12	32	50	95	40	37	M10×1.0	3.40
	HSK100A-HC14-95	14	34	50	95	40	37	M10×1.0	3.40
	HSK100A-HC16-100	16	38	50	100	46	42	M12×1.0	3.50
	HSK100A-HC18-100	18	40	50	100	46	42	M12×1.0	3.60
	HSK100A-HC20-105	20	42	50	105	48	42	M16×1.0	4.00
	HSK100A-HC25-110	25	57	63	110	59	48	M16×1.0	4.20
HSK100A-HC32-110	32	64	75	110	63	55	M16×1.0	4.30	

► In case of Hydraulic Chuck with $\varnothing 12$, $\varnothing 20$ and $\varnothing 32$ ID, various cutting tools with different dia. can be used together with Hydraulic Chuck collet(reduction sleeve).

HYDRAULIC CHUCK COLLET (REDUCTION SLEEVE)

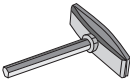
HK COLLET	CODE No.	T-WRENCH	CODE No.
	HK12		T-4
	HK20		T-5
	HK32		

HYDRAULIC CHUCK (Radial tool length pre-setting type) HYDRAULIK SPANNFUTTER (Radiale Werkzeuglängen Voreinstellung)

 TOOL
HOLDERS

DIN 69871-SK FORM AD/B

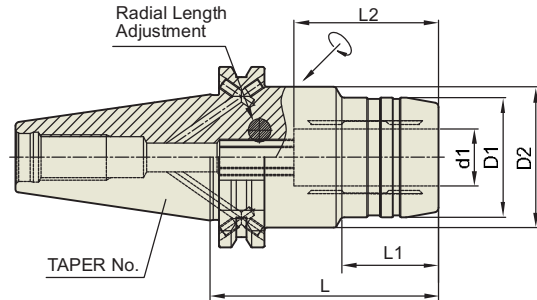
 DIN 69871
- SK

 Taper
Accuracy
AT3

 G Value
2.5

 RPM
20,000

 Coolant
System
AD/B

TAPER No.	CODE No.	d1	D1	D2	L	L1	L 2	Weight (kg)
30	SK30AD/B-HCR12-85	12	32	44.5	85	40	37	0.90
	SK30AD/B-HCR20-85	20	44	44	85	-	42	1.00
40	SK40AD/B-HCR12-80.5	12	32	49.5	80.5	31.5	37	1.50
	SK40AD/B-HCR20-80.5	20	42	49.5	80.5	34	42	1.60
	SK40AD/B-HCR32-110	32	63	80	110	50	55	2.20
50	SK50AD/B-HCR12-80.5	12	32	49.5	80.5	31.5	37	3.90
	SK50AD/B-HCR20-80.5	20	42	49.5	80.5	34	42	4.00
	SK50AD/B-HCR32-100	32	60	60	100	-	55	4.70

▶ In case of SK50, balancing grade shall be guaranteed up to G2.5/15,000rpm.

▶ Higher balancing grade product up to G2.5/40,000(G6.3/100,000rpm) could be supplied by customer's request.

HYDRAULIC CHUCK (SHORT & HEAVY) HYDRAULIK SPANNFUTTER (KURZ und SCHWER)

DIN 69871-SK FORM AD/B

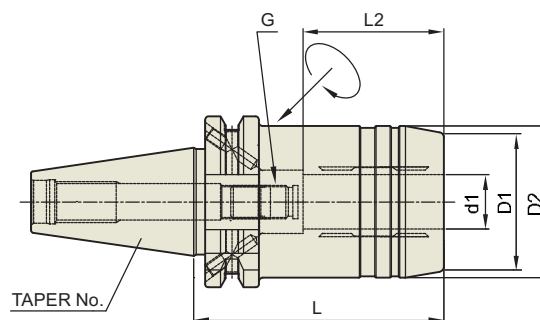

DIN 69871 -SK	Taper Accuracy AT3	G Value 2.5	RPM 20,000	Coolant System AD/B
------------------	--------------------------	----------------	---------------	---------------------------

TAPER No.	CODE No.	d1	D1	D2	L	L 2	G	Weight (kg)
30	SK30AD/B-HC20S-85	20	41	44	85	42	M10×1.0	0.53
40	SK40AD/B-HC20S-64.5	20	37	49.5	64.5	42	M16×1.0	1.26
50	SK50AD/B-HC20S-81	20	37	49.5	81	42	M16×1.0	3.65
	SK50AD/B-HC32S-81	32	55	72	81	55	M16×1.0	3.87

- ▶ In case of SK50, balancing grade shall be guaranteed up to G2.5/15,000rpm.
- ▶ Higher balancing grade product up to G2.5/40,000(G6.3/100,000rpm) could be supplied by customer's request.

HYDRAULIC CHUCK (SLIM) HYDRAULIK SPANNFUTTER (SCHLANK)

 TOOL
HOLDERS

DIN 69871-SK FORM AD/B

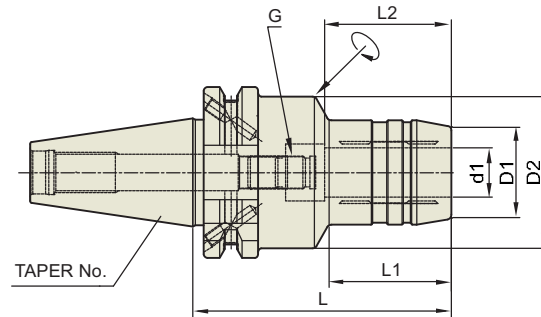
 DIN 69871
- SK

 Taper
Accuracy
AT3

 G Value
2.5

 RPM
20,000

 Coolant
System
AD/B

TAPER No.	CODE No.	d1	D1	D2	L	L1	L2	G	Weight (kg)
30	SK30AD/B-HC6-70	6	26	44.5	70	29.5	27	M5×0.8	0.65
	SK30AD/B-HC8-70	8	28	44.5	70	30	27	M6×1.0	0.65
	SK30AD/B-HC10-75	10	30	44.5	75	31	32	M8×1.0	0.73
	SK30AD/B-HC12-85	12	32	44.5	85	40	37	M10×1.0	0.80
	SK30AD/B-HC14-85	14	34	44.5	85	40	37	M10×1.0	0.80
	SK30AD/B-HC16-90	16	38	44.5	90	46	42	M12×1.0	0.90
	SK30AD/B-HC18-90	18	40	44.5	90	46	42	M12×1.0	0.90
SK30AD/B-HC20-90	20	42	44.5	90	48	42	M16×1.0	0.90	
40	SK40AD/B-HC6-80.5	6	22	26	80.5	30	27	M5×0.8	1.31
	SK40AD/B-HC6-110	6	22	26	110	30	27	M5×0.8	1.76
	SK40AD/B-HC8-80.5	8	24	28	80.5	30	27	M12×1.0	1.34
	SK40AD/B-HC8-110	8	24	28	110	30	27	M6×1.0	1.76
	SK40AD/B-HC10-80.5	10	26	30	80.5	32	32	M8×1.0	1.34
	SK40AD/B-HC10-110	10	26	30	110	32	32	M8×1.0	1.76
	SK40AD/B-HC12-80.5	12	28	32	80.5	35	37	M10×1.0	1.34
	SK40AD/B-HC12-110	12	28	32	110	35	37	M10×1.0	1.76
	SK40AD/B-HC16-80.5	16	34	38	80.5	40	42	M12×1.0	1.34
	SK40AD/B-HC16-110	16	34	38	110	40	42	M12×1.0	1.76
	SK40AD/B-HC20-80.5	20	38	42	80.5	40	42	M16×1.0	1.35
	SK40AD/B-HC20-110	20	38	42	110	40	42	M16×1.0	1.78
SK40AD/B-HC25-80.5	25	46	50	80.5	45	48	M16×1.0	1.75	
SK40AD/B-HC32-110	32	56	60	110	50	55	M16×1.0	2.60	
50	SK50AD/B-HC6-80.5	6	22	26	80.5	30	27	M5×0.8	3.00
	SK50AD/B-HC8-80.5	8	24	28	80.5	30	27	M6×1.0	3.00
	SK50AD/B-HC10-80.5	10	26	30	80.5	32	32	M8×1.0	3.00
	SK50AD/B-HC12-80.5	12	28	32	80.5	35	37	M10×1.0	3.05
	SK50AD/B-HC16-80.5	16	34	38	80.5	40	42	M12×1.0	3.10
SK50AD/B-HC20-80.5	20	38	42	80.5	40	42	M16×1.0	3.15	

▶ In case of SK50, balancing grade shall be guaranteed up to G2.5/15,000rpm.

▶ Higher balancing grade product up to G2.5/40,000(G6.3/100,000rpm) could be supplied by customer's request.

HYDRAULIC MOLD CHUCK HYDRAULIK SPANNFUTTER FÜR DEN FORMENBAU

MAS403-BT FORM AD/B

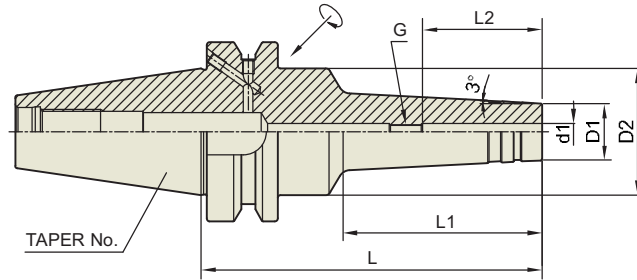

MAS403 -BT	Taper Accuracy AT3	G Value 2.5	RPM 20,000	Coolant System AD/B
---------------	--------------------------	----------------	---------------	---------------------------

TAPER No.	CODE No.	d1	D1	D2	L	L1	L2	G	Weight (kg)
40	BT40AD/B-HMC6-120	6	20	44.5	120	70	27	M5×0.8	1.40
	BT40AD/B-HMC6-150	6	20	44.5	150	100	27	M5×0.8	1.65
	BT40AD/B-HMC8-120	8	22	44.5	120	70	27	M6×1.0	1.40
	BT40AD/B-HMC8-150	8	22	44.5	150	100	27	M6×1.0	1.65
	BT40AD/B-HMC10-120	10	24	44.5	120	70	32	M8×1.0	1.40
	BT40AD/B-HMC10-150	10	24	44.5	150	100	32	M8×1.0	1.65
	BT40AD/B-HMC12-120	12	25	44.5	120	70	37	M10×1.0	1.40
	BT40AD/B-HMC12-150	12	25	44.5	150	100	37	M10×1.0	1.65
	BT40AD/B-HMC16-120	16	32	44.5	120	70	42	M12×1.0	1.45
	BT40AD/B-HMC16-150	16	32	44.5	150	100	42	M12×1.0	1.70
	BT40AD/B-HMC20-120	20	34	44	120	-	42	M16×1.0	1.50
BT40AD/B-HMC20-150	20	34	47	150	-	42	M16×1.0	1.80	
50	BT50AD/B-HMC6-150	6	20	50	150	90	27	M5×0.8	4.70
	BT50AD/B-HMC8-150	8	22	50	150	90	27	M6×1.0	4.70
	BT50AD/B-HMC10-150	10	24	50	150	90	32	M8×1.0	4.70
	BT50AD/B-HMC12-150	12	25	37	150	-	37	M10×1.0	4.70
	BT50AD/B-HMC16-150	16	32	44	150	-	42	M12×1.0	4.90
	BT50AD/B-HMC20-150	20	34	46	150	-	42	M16×1.0	5.00

► In case of BT50, balancing grade shall be guaranteed up to G2.5/15,000rpm.

► Higher balancing grade product up to G2.5/40,000 (G6.3/100,000rpm) could be supplied by customer's request.



HYDRAULIC MOLD CHUCK HYDRAULIK SPANNFUTTER FÜR DEN FORMENBAU

TOOL
HOLDERS

DIN69893-HSK FORM A

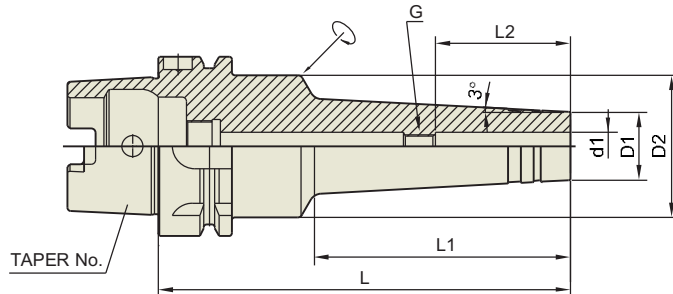

DIN69893 - HSK	Taper Accuracy AT3	G Value 2.5	RPM 20,000	Coolant System
-------------------	--------------------------	----------------	---------------	-------------------

TAPER No.	CODE No.	d1	D1	D2	L	L1	L2	G	Weight (kg)
63A	HSK63A-HMC6-145	6	20	50	145	90	27	M5×0.8	1.40
	HSK63A-HMC8-145	8	22	50	145	90	27	M6×1.0	1.40
	HSK63A-HMC10-145	10	24	50	145	90	32	M8×1.0	1.40
	HSK63A-HMC12-145	12	25	50	145	90	37	M10×1.0	1.40
	HSK63A-HMC16-145	16	32	50	145	90	42	M12×1.0	1.45
	HSK63A-HMC20-145	20	34	50	145	90	42	M16×1.0	1.50
100A	HSK100A-HMC6-150	6	20	50	150	90	27	M5×0.8	4.50
	HSK100A-HMC8-150	8	22	50	150	90	27	M6×1.0	4.50
	HSK100A-HMC10-150	10	24	50	150	90	32	M8×1.0	4.50
	HSK100A-HMC12-150	12	25	50	150	90	37	M10×1.0	4.50
	HSK100A-HMC16-150	16	32	50	150	90	42	M12×1.0	4.70
	HSK100A-HMC20-150	20	34	50	150	90	42	M16×1.0	5.00

- ▶ In case of HSK100A, balancing grade shall be guaranteed up to G2.5/15,000rpm.
- ▶ Higher balancing grade product up to G2.5/40,000(G6.3/100,000rpm) could be supplied by customer's request.

HYDRAULIC MOLD CHUCK HYDRAULIK SPANNFUTTER FÜR DEN FORMENBAU

DIN 69871-SK FORM AD/B

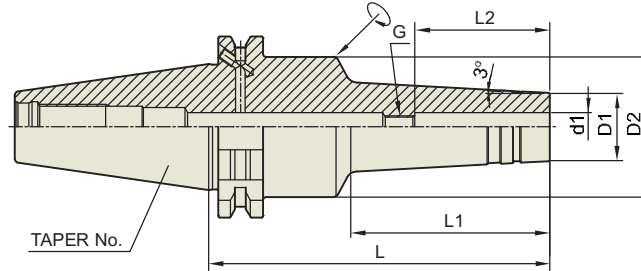

DIN 69871 -SK	Taper Accuracy AT3	G Value 2.5	RPM 20,000	Coolant System AD/B
------------------	--------------------------	----------------	---------------	---------------------------

TAPER No.	CODE No.	d1	D1	D2	L	L1	L2	G	Weight (kg)
40	SK40AD/B-HMC6-120	6	20	49.5	120	70	27	M5×0.8	1.40
	SK40AD/B-HMC6-150	6	20	49.5	150	100	27	M5×0.8	1.65
	SK40AD/B-HMC8-120	8	22	49.5	120	70	27	M6×1.0	1.40
	SK40AD/B-HMC8-150	8	22	49.5	150	100	27	M6×1.0	1.65
	SK40AD/B-HMC10-120	10	24	49.5	120	70	32	M8×1.0	1.40
	SK40AD/B-HMC10-150	10	24	49.5	150	100	32	M8×1.0	1.65
	SK40AD/B-HMC12-120	12	25	49.5	120	70	37	M10×1.0	1.40
	SK40AD/B-HMC12-150	12	25	49.5	150	100	37	M10×1.0	1.65
	SK40AD/B-HMC16-120	16	32	49.5	120	70	42	M12×1.0	1.45
	SK40AD/B-HMC16-150	16	32	49.5	150	100	42	M12×1.0	1.70
	SK40AD/B-HMC20-120	20	34	49.5	120	70	42	M16×1.0	1.50
SK40AD/B-HMC20-150	20	34	49.5	150	100	42	M16×1.0	1.70	
50	SK50AD/B-HMC6-150	6	20	49.5	150	90	27	M5×0.8	4.50
	SK50AD/B-HMC8-150	8	22	49.5	150	90	27	M6×1.0	4.50
	SK50AD/B-HMC10-150	10	24	49.5	150	90	32	M8×1.0	4.50
	SK50AD/B-HMC12-150	12	25	49.5	150	90	37	M10×1.0	4.50
	SK50AD/B-HMC16-150	16	32	49.5	150	90	42	M12×1.0	4.70
	SK50AD/B-HMC20-150	20	34	49.5	150	90	42	M16×1.0	5.00

▶ In case of SK50, balancing grade shall be guaranteed up to G2.5/15,000rpm.

▶ Higher balancing grade product up to G2.5/40,000(G6.3/100,000rpm) could be supplied by customer's request.



HYDRAULIC CHUCK (Exclusive use for grinder) HYDRAULIK SPANNFUTTER (für Schleifmaschine)

TOOL
HOLDERS

MTB

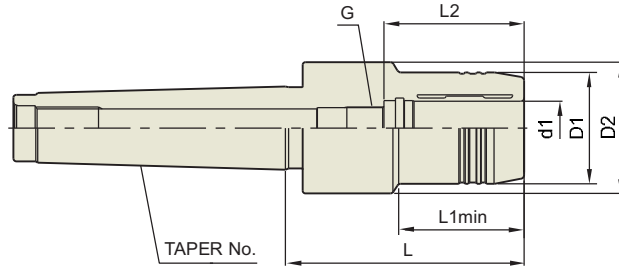

MTB	Taper Accuracy AT3	G Value	RPM	Coolant System
-----	-----------------------	---------	-----	----------------

TAPER No.	CODE No.	d1	D1	D2	L	L1	L 2	G	Weight (kg)
MT4	MTB4-HC20-90	20	42	49.5	90	47.5	53	M6×1.0	1.30
	MTB4-HC32S-90	32	72	72	90	-	75	-	1.40
MT5	MTB5-HC20-90	20	42	49.5	90	47.5	53	-	2.20
	MTB5-HC32S-90	32	72	72	90	-	100	-	2.40

DIN 69871 - SK FORM A

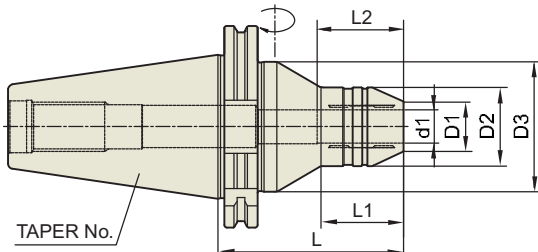

DIN 69871 - SK	Taper Accuracy AT3	G Value 2.5	RPM 15,000	Coolant System
----------------	-----------------------	----------------	---------------	----------------

TAPER No.	CODE No.	d1	D1	D2	D3	L	L1	L 2	Weight (kg)
50	SK50-HC6G-90	6	14	30	63	90	30	27	3.00
	SK50-HC8G-90	8	16	30	63	90	30	27	3.00
	SK50-HC10G-90	10	18	30	63	90	30	32	3.00
	SK50-HC12G-90	12	21	33	63	90	35	37	3.05
	SK50-HC14G-90	14	22	35	63	90	35	37	3.10
	SK50-HC16G-90	16	24	38	63	90	40	42	3.10
	SK50-HC18G-90	18	26	40	63	90	40	42	3.10
	SK50-HC20G-110	20	29	42	63	110	40	42	3.30
	SK50-HC25G-110	25	34	50	70	110	45	48	3.60
SK50-HC32G-110	32	42	56	80	110	50	55	4.20	

HYDRAULIC CHUCK COLLET (REDUCTION SLEEVE)

HK COLLET	CODE No.	T-WRENCH	CODE No.
	HK12		T-4
	HK20		T-5
	HK32		

HYDRAULIC CHUCK COLLET (REDUCTION SLEEVE) HYDRAULIK SPANNFUTTER SPANNZANGE (Geschlitzte Zwischenbuchse)

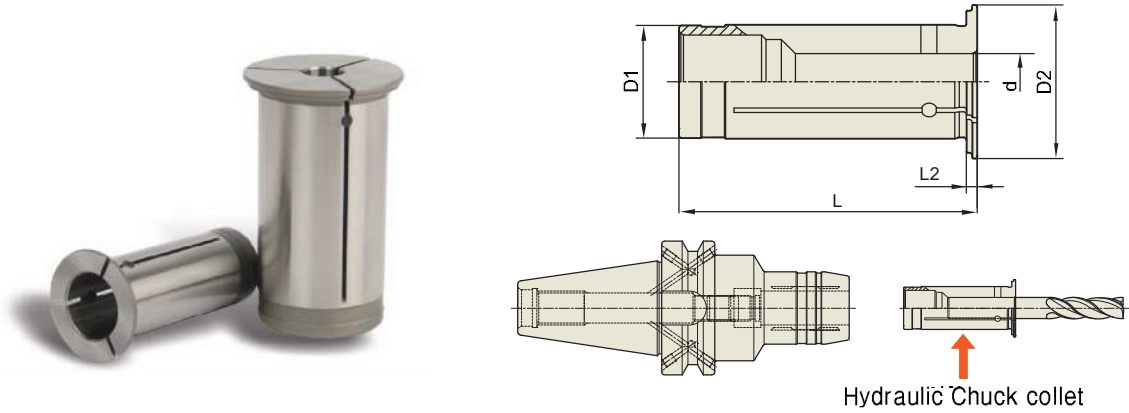

CODE No.		d	D1	D2	L	L2
HK12	3	3	12	19	47	2
	4	4	12	19	47	2
	5	5	12	19	47	2
	6	6	12	19	47	2
	7	7	12	19	47	2
	8	8	12	19	47	2
HK20	3	3	20	24	50.5	2
	4	4	20	24	50.5	2
	5	5	20	24	50.5	2
	6	6	20	24	50.5	2
	7	7	20	24	50.5	2
	8	8	20	24	50.5	2
	9	9	20	24	50.5	2
	10	10	20	24	50.5	2
	11	11	20	24	50.5	2
	12	12	20	24	50.5	2
	13	13	20	24	50.5	2
HK32	6	6	32	36	60.5	3
	8	8	32	36	60.5	3
	10	10	32	36	60.5	3
	12	12	32	36	60.5	3
	14	14	32	36	60.5	3
	16	16	32	36	60.5	3
	18	18	32	36	60.5	3
	20	20	32	36	60.5	3
25	25	32	36	60.5	3	

▶ Other special sizes of Hydraulic Chuck collets could be produced and supplied .

- ▶ **FEATURE** : Hydraulic Chuck collet(reduction sleeve) is divided into trisection by high precision wire cutting, which guarantees high precision ID.
- ▶ **CHUCKING METHOD** : Please assemble cutting tool with collet firstly, and then insert collet into Hydraulic Chuck.

SHRINK FIT HOLDER SCHRUMPFUTTER

 TOOL
HOLDERS

MAS403-BT FORM AD/B

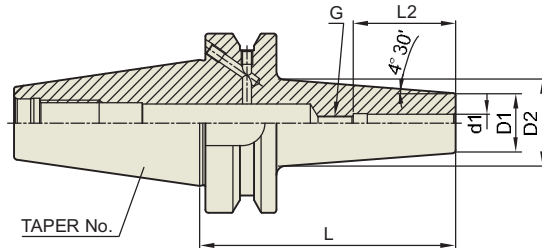

MAS403 -BT	Taper Accuracy AT3	G Value 2.5	RPM 20,000	Coolant System AD/B
---------------	--------------------------	----------------	---------------	---------------------------

TAPER No.	CODE No.	d1	D1	D2	L	L 2	G	Weight (kg)
30	BT30AD/B-SFH3-60	3	11	17	60	19	-	0.40
	BT30AD/B-SFH4-60	4	11	17	60	22	-	0.40
	BT30AD/B-SFH5-60	5	13	19	60	28	-	0.40
	BT30AD/B-SFH6-60	6	21	27	60	36	M5×0.8	0.40
	BT30AD/B-SFH8-60	8	21	27	60	36	M6×1.0	0.40
	BT30AD/B-SFH10-80	10	24	33	80	42	M8×1.0	0.40
	BT30AD/B-SFH12-80	12	24	33	80	47	M10×1.0	0.42
	BT30AD/B-SFH16-80	16	27	36	80	50	M12×1.0	0.42
BT30AD/B-SFH20-90	20	33	44	90	52	M16×1.0	0.44	
40	BT40AD/B-SFH3-90	3	11	21	90	19	-	1.00
	BT40AD/B-SFH4-90	4	11	21	90	22	-	1.00
	BT40AD/B-SFH5-90	5	13	23	90	28	-	1.00
	BT40AD/B-SFH6-90	6	21	31	90	36	M5×0.8	1.10
	BT40AD/B-SFH6-160	6	21	31	160	36	M5×0.8	1.15
	BT40AD/B-SFH8-90	8	21	31	90	36	M6×1.0	1.11
	BT40AD/B-SFH8-160	8	21	31	160	36	M6×1.0	1.15
	BT40AD/B-SFH10-90	10	24	34	90	42	M8×1.0	1.10
	BT40AD/B-SFH10-160	10	24	34	160	42	M8×1.0	1.15
	BT40AD/B-SFH12-90	12	24	34	90	47	M10×1.0	1.10
	BT40AD/B-SFH12-160	12	24	34	160	47	M10×1.0	1.15
	BT40AD/B-SFH14-90	14	27	37	90	47	M10×1.0	1.20
	BT40AD/B-SFH14-160	14	27	37	160	47	M10×1.0	1.50
	BT40AD/B-SFH16-90	16	27	37	90	50	M12×1.0	1.20
	BT40AD/B-SFH16-160	16	27	37	160	50	M12×1.0	1.50
	BT40AD/B-SFH18-90	18	33	43	90	50	M12×1.0	1.30
	BT40AD/B-SFH18-160	18	33	43	160	50	M12×1.0	1.60
	BT40AD/B-SFH20-90	20	33	43	90	52	M16×1.0	1.40
	BT40AD/B-SFH20-160	20	33	43	160	52	M16×1.0	1.70
	BT40AD/B-SFH25-100	25	44	55	100	58	M16×1.0	1.70
BT40AD/B-SFH25-160	25	44	57	160	58	M16×1.0	2.00	

▶ Higher balancing grade product up to G2.5/40,000(G6.3/100,000rpm) could be supplied by customer's request.

SHRINK FIT HOLDER SCHRUMPFUTTER

MAS403-BT FORM AD/B

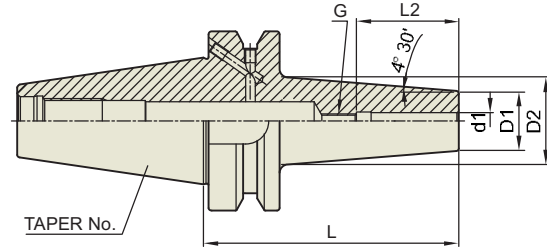

MAS403 -BT	Taper Accuracy AT3	G Value 2.5	RPM 20,000	Coolant System AD/B
---------------	--------------------------	----------------	---------------	---------------------------

TAPER No.	CODE No.	d1	D1	D2	L	L 2	G	Weight (kg)
50	BT50AD/B-SFH3-100	3	11	21	100	19	-	1.50
	BT50AD/B-SFH4-100	4	11	21	100	22	-	1.50
	BT50AD/B-SFH5-100	5	13	23	100	28	-	1.50
	BT50AD/B-SFH6-100	6	21	31	100	36	M5×0.8	1.50
	BT50AD/B-SFH6-160	6	21	31	160	36	M5×0.8	2.00
	BT50AD/B-SFH8-100	8	21	31	100	36	M6×1.0	1.50
	BT50AD/B-SFH8-160	8	21	31	160	36	M6×1.0	2.00
	BT50AD/B-SFH10-100	10	24	34	100	42	M8×1.0	1.50
	BT50AD/B-SFH10-160	10	24	34	160	42	M8×1.0	2.00
	BT50AD/B-SFH12-100	12	24	34	100	47	M10×1.0	1.50
	BT50AD/B-SFH12-160	12	24	34	160	47	M10×1.0	2.00
	BT50AD/B-SFH14-100	14	27	37	100	47	M10×1.0	1.60
	BT50AD/B-SFH14-160	14	27	37	160	47	M10×1.0	2.10
	BT50AD/B-SFH16-100	16	27	37	100	50	M12×1.0	1.60
	BT50AD/B-SFH16-160	16	27	37	160	50	M12×1.0	2.10
	BT50AD/B-SFH18-100	18	33	43	100	50	M12×1.0	1.60
	BT50AD/B-SFH18-160	18	33	43	160	50	M12×1.0	2.00
	BT50AD/B-SFH20-100	20	33	43	100	52	M16×1.0	1.80
BT50AD/B-SFH20-160	20	33	43	160	52	M16×1.0	2.20	
BT50AD/B-SFH25-100	25	44	54	100	58	M16×1.0	2.00	
BT50AD/B-SFH25-160	25	44	57	160	58	M16×1.0	2.40	

► Higher balancing grade product up to G2.5/40,000(G6.3/100,000rpm) could be supplied by customer's request.

SHRINK FIT HOLDER SCHRUMPFUTTER

 TOOL
HOLDERS

DIN69893-HSK FORM A

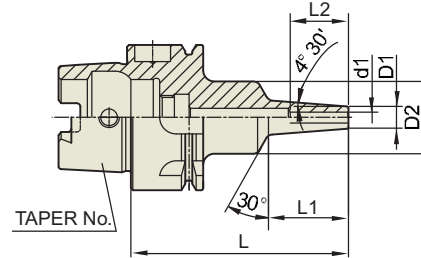

DIN69893 - HSK	Taper Accuracy AT3	G Value 2.5	RPM 20,000	Coolant System
-------------------	--------------------------	----------------	---------------	-------------------

TAPER No.	CODE No.	d1	D1	D2	L	L1	L 2	Weight (kg)
40A	HSK40A-SFH3-60	3	11	17	60	22	16	0.30
	HSK40A-SFH3-80	3	11	17	80	42	16	0.40
	HSK40A-SFH4-60	4	11	17	60	22	16.5	0.30
	HSK40A-SFH4-80	4	11	17	80	42	16.5	0.40
	HSK40A-SFH5-60	5	13	19	60	22	17	0.30
	HSK40A-SFH5-80	5	13	19	80	42	17	0.40
	HSK40A-SFH6-60	6	21	27	60	22	24	0.40
	HSK40A-SFH6-80	6	21	27	80	42	24	0.50
	HSK40A-SFH8-70	8	21	27	70	22	25	0.40
	HSK40A-SFH8-90	8	21	27	90	42	25	0.50
	HSK40A-SFH10-70	10	24	33	70	22	32	0.50
HSK40A-SFH10-90	10	24	33	90	42	32	0.60	

► Higher balancing grade product up to G2.5/40,000(G6.3/100,000rpm) could be supplied by customer's request.

DIN69893-HSK FORM E

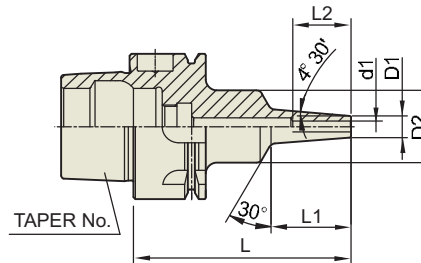

TAPER No.	CODE No.	d1	D1	D2	L	L1	L 2	Weight (kg)
40E	HSK40E-SFH3-50	3	11	17	50	22	16	0.30
	HSK40E-SFH3-70	3	11	17	70	42	16	0.40
	HSK40E-SFH4-50	4	11	17	50	22	16.5	0.30
	HSK40E-SFH4-70	4	11	17	70	42	16.5	0.40
	HSK40E-SFH5-50	5	13	19	50	22	17	0.30
	HSK40E-SFH5-70	5	13	19	70	42	17	0.40
	HSK40E-SFH6-50	6	21	27	50	22	24	0.40
	HSK40E-SFH6-70	6	21	27	70	42	24	0.50
	HSK40E-SFH8-60	8	21	27	60	22	25	0.40
	HSK40E-SFH8-80	8	21	27	80	42	25	0.50
	HSK40E-SFH10-60	10	24	33	60	22	32	0.50
	HSK40E-SFH10-80	10	24	33	80	42	32	0.60

► Higher balancing grade product up to G2.5/40,000(G6.3/100,000rpm) could be supplied by customer's request.

SHRINK FIT HOLDER SCHRUMPFUTTER

DIN69893-HSK FORM A

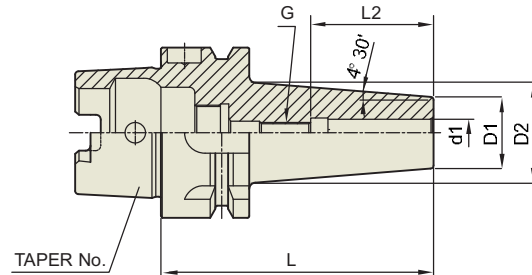

DIN69893 - HSK	Taper Accuracy AT3	G Value 2.5	RPM 20,000	Coolant System
-------------------	--------------------------	----------------	---------------	-------------------

TAPER No.	CODE No.	d1	D1	D2	L	L 2	G	Weight (kg)
50A	HSK50A-SFH3-80	3	11	19.5	80	19	-	0.54
	HSK50A-SFH4-80	4	11	19.5	80	22	-	0.55
	HSK50A-SFH5-80	5	13	21.5	80	28	-	0.56
	HSK50A-SFH6-80	6	21	29.5	80	36	M5×0.8	0.57
	HSK50A-SFH8-80	8	21	29.5	80	36	M6×1.0	0.58
	HSK50A-SFH10-85	10	24	33	85	42	M8×1.0	0.65
	HSK50A-SFH12-90	12	24	34	90	47	M10×1.0	0.67
	HSK50A-SFH14-90	14	27	37	90	47	M10×1.0	0.72
	HSK50A-SFH16-95	16	27	38	95	50	M12×1.0	0.73
	HSK50A-SFH18-95	18	33	44	95	50	M12×1.0	0.90
HSK50A-SFH20-100	20	33	45	100	52	M16×1.0	0.92	
63A	HSK63A-SFH3-80	3	11	19.5	80	19	-	0.70
	HSK63A-SFH4-80	4	11	19.5	80	22	-	0.70
	HSK63A-SFH5-80	5	13	21.5	80	28	-	0.70
	HSK63A-SFH6-80	6	21	29.5	80	36	M5×0.8	0.83
	HSK63A-SFH6-160	6	21	32	160	36	M5×0.8	1.00
	HSK63A-SFH8-80	8	21	29.5	80	36	M6×1.0	0.83
	HSK63A-SFH8-160	8	21	32	160	36	M6×1.0	0.00
	HSK63A-SFH10-85	10	24	33	85	42	M8×1.0	0.83
	HSK63A-SFH10-160	10	24	34	160	42	M8×1.0	0.00
	HSK63A-SFH12-90	12	24	34	90	47	M10×1.0	0.83
	HSK63A-SFH12-160	12	24	34	160	47	M10×1.0	0.00
	HSK63A-SFH14-90	14	27	37	90	47	M10×1.0	0.91
	HSK63A-SFH14-160	14	27	38	160	47	M10×1.0	1.30
	HSK63A-SFH16-95	16	27	38	95	50	M12×1.0	0.98
	HSK63A-SFH16-160	16	27	38	160	50	M12×1.0	1.40
	HSK63A-SFH18-95	18	33	44	95	50	M12×1.0	0.98
	HSK63A-SFH18-160	18	33	45	160	50	M12×1.0	1.40
	HSK63A-SFH20-100	20	33	45	100	52	M16×1.0	1.00
	HSK63A-SFH20-160	20	33	45	160	52	M16×1.0	1.40
	HSK63A-SFH25-115	25	44	58	115	58	M16×1.0	1.40
HSK63A-SFH25-160	25	44	58	160	58	M16×1.0	1.80	

► Higher balancing grade product up to G2.5/40,000(G6.3/100,000rpm) could be supplied by customer's request.

SHRINK FIT HOLDER SCHRUMPFUTTER

 TOOL
HOLDERS

DIN69893-HSK FORM A

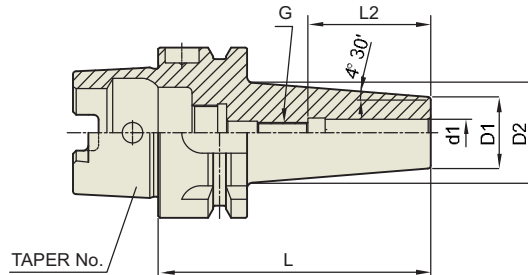
 DIN69893
- HSK

 Taper
Accuracy
AT3

 G Value
2.5

 RPM
20,000

 Coolant
System

TAPER No.	CODE No.	d1	D1	D2	L	L 2	G	Weight (kg)
100A	HSK100A-SFH3-85	3	11	20	85	19	-	1.30
	HSK100A-SFH4-85	4	11	20	85	22	-	1.30
	HSK100A-SFH5-85	5	13	22	85	28	-	1.30
	HSK100A-SFH6-85	6	21	30	85	36	M5×0.8	1.30
	HSK100A-SFH6-160	6	21	32	160	36	M5×0.8	1.80
	HSK100A-SFH8-85	8	21	30	85	36	M6×1.0	1.30
	HSK100A-SFH8-160	8	21	32	160	36	M6×1.0	1.80
	HSK100A-SFH10-90	10	24	34	90	42	M8×1.0	1.30
	HSK100A-SFH10-160	10	24	35	160	42	M8×1.0	1.80
	HSK100A-SFH12-95	12	24	34	95	47	M10×1.0	1.30
	HSK100A-SFH12-160	12	24	35	160	47	M10×1.0	1.80
	HSK100A-SFH14-95	14	27	37	95	47	M10×1.0	1.40
	HSK100A-SFH14-160	14	27	39	160	47	M10×1.0	1.90
	HSK100A-SFH16-100	16	27	38	100	50	M12×1.0	1.40
	HSK100A-SFH16-160	16	27	39	160	50	M12×1.0	1.90
	HSK100A-SFH18-100	18	33	44	100	50	M12×1.0	1.50
	HSK100A-SFH18-160	18	33	45	160	50	M12×1.0	2.00
	HSK100A-SFH20-100	20	33	44	100	52	M16×1.0	1.50
	HSK100A-SFH20-160	20	33	45	160	52	M16×1.0	2.00
HSK100A-SFH25-115	25	44	53	115	58	M16×1.0	1.80	
HSK100A-SFH25-160	25	44	53	160	58	M16×1.0	2.30	

TOOL
HOLDERS

SHRINK FIT HOLDER SCHRUMPFUTTER

DIN69871-SK FORM AD/B

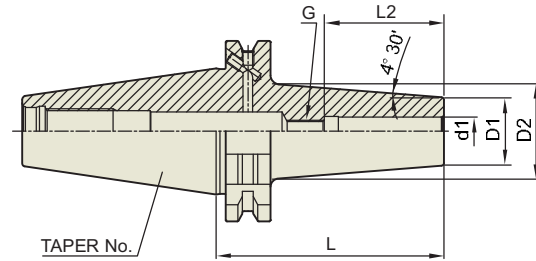

DIN69871 -SK	Taper Accuracy AT3	G Value 2.5	RPM 20,000	Coolant System AD/B
-----------------	--------------------------	----------------	---------------	---------------------------

TAPER No.	CODE No.	d1	D1	D2	L	L 2	G	Weight (kg)
30	SK30AD/B-SFH3-60	3	11	17	60	19	-	0.40
	SK30AD/B-SFH4-60	4	11	17	60	22	-	0.40
	SK30AD/B-SFH5-60	5	13	19	60	28	-	0.40
	SK30AD/B-SFH6-60	6	21	27	60	36	M5×0.8	0.40
	SK30AD/B-SFH8-60	8	21	27	60	36	M6×1.0	0.40
	SK30AD/B-SFH10-80	10	24	34	80	42	M8×1.0	0.40
	SK30AD/B-SFH12-80	12	24	34	80	47	M10×1.0	0.42
	SK30AD/B-SFH16-80	16	27	37	80	50	M12×1.0	0.42
SK30AD/B-SFH20-90	20	33	44	90	52	M16×1.0	0.44	
40	SK40AD/B-SFH3-80	3	11	21	80	19	-	1.00
	SK40AD/B-SFH4-80	4	11	21	80	22	-	1.00
	SK40AD/B-SFH5-80	5	13	23	80	28	-	1.00
	SK40AD/B-SFH6-80	6	21	31	80	36	M5×0.8	1.10
	SK40AD/B-SFH6-160	6	21	32	160	36	M5×0.8	1.15
	SK40AD/B-SFH8-80	8	21	31	80	36	M6×1.0	1.11
	SK40AD/B-SFH8-160	8	21	32	160	36	M6×1.0	1.15
	SK40AD/B-SFH10-80	10	24	34	80	42	M8×1.0	1.10
	SK40AD/B-SFH10-160	10	24	34	160	42	M8×1.0	1.15
	SK40AD/B-SFH12-80	12	24	34	80	47	M10×1.0	1.10
	SK40AD/B-SFH12-160	12	24	34	160	47	M10×1.0	1.15
	SK40AD/B-SFH14-80	14	27	37	80	47	M10×1.0	1.20
	SK40AD/B-SFH14-160	14	27	36	160	47	M10×1.0	1.50
	SK40AD/B-SFH16-80	16	27	37	80	50	M12×1.0	1.20
	SK40AD/B-SFH16-160	16	27	36	160	50	M12×1.0	1.50
	SK40AD/B-SFH18-80	18	33	43	80	50	M12×1.0	1.30
	SK40AD/B-SFH18-160	18	33	44	160	50	M12×1.0	1.60
	SK40AD/B-SFH20-80	20	33	43	80	52	M16×1.0	1.40
	SK40AD/B-SFH20-160	20	33	44	160	52	M16×1.0	1.70
	SK40AD/B-SFH25-90	25	44	55	90	58	M16×1.0	1.70
SK40AD/B-SFH25-160	25	44	53	160	58	M16×1.0	2.00	

► Higher balancing grade product up to G2.5/40,000(G6.3/100,000rpm) could be supplied by customer's request.



**SHRINK FIT HOLDER
SCHRUMPFUTTER**

TOOL
HOLDERS

DIN69871-SK FORM AD/B

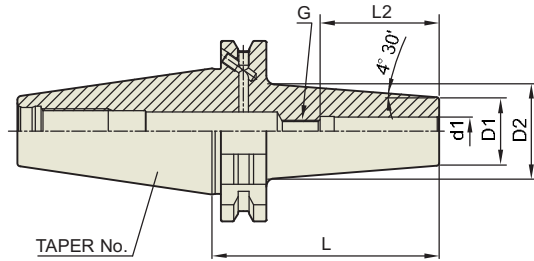

DIN69871 -SK	Taper Accuracy AT3	G Value 2.5	RPM 20,000	Coolant System AD/B
-----------------	--------------------------	----------------	---------------	---------------------------

TAPER No.	CODE No.	d1	D1	D2	L	L 2	G	Weight (kg)
50	SK50AD/B-SFH3-80	3	11	21	80	19	-	1.50
	SK50AD/B-SFH4-80	4	11	21	80	22	-	1.50
	SK50AD/B-SFH5-80	5	13	23	80	28	-	1.50
	SK50AD/B-SFH6-80	6	21	31	80	36	M5×0.8	1.50
	SK50AD/B-SFH6-160	6	21	32	160	36	M5×0.8	2.00
	SK50AD/B-SFH8-80	8	21	31	80	36	M6×1.0	1.50
	SK50AD/B-SFH8-160	8	21	32	160	36	M6×1.0	2.00
	SK50AD/B-SFH10-80	10	24	34	80	42	M8×1.0	1.50
	SK50AD/B-SFH10-160	10	24	34	160	42	M8×1.0	2.00
	SK50AD/B-SFH12-80	12	24	34	80	47	M10×1.0	1.50
	SK50AD/B-SFH12-160	12	24	34	160	47	M10×1.0	2.00
	SK50AD/B-SFH14-80	14	27	37	80	47	M10×1.0	1.60
	SK50AD/B-SFH14-160	14	27	36	160	47	M10×1.0	2.10
	SK50AD/B-SFH16-80	16	27	37	80	50	M12×1.0	1.60
	SK50AD/B-SFH16-160	16	27	36	160	50	M12×1.0	2.10
	SK50AD/B-SFH18-80	18	33	43	80	50	M12×1.0	1.60
	SK50AD/B-SFH18-160	18	33	44	160	50	M12×1.0	2.00
	SK50AD/B-SFH20-80	20	33	43	80	52	M16×1.0	1.80
SK50AD/B-SFH20-160	20	33	44	160	52	M16×1.0	2.20	
SK50AD/B-SFH25-90	25	44	53	90	58	M16×1.0	2.00	
SK50AD/B-SFH25-160	25	44	53	160	58	M16×1.0	2.40	

► Higher balancing grade product up to G2.5/40,000(G6.3/100,000rpm) could be supplied by customer's request.

SHRINK FIT HOLDER SCHRUMPFUTTER

EXTENSION (VERLÄNGERUNG)

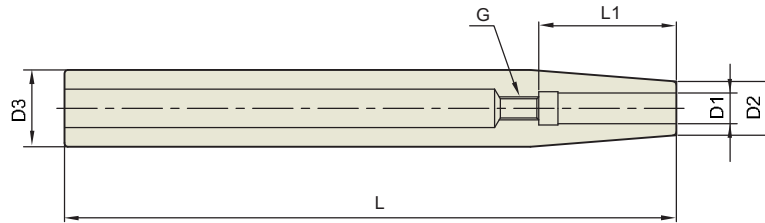

EXT.	Taper Accuracy AT3	G Value	RPM	Coolant System
------	-----------------------	---------	-----	----------------

STANDARD

TAPER No.	CODE No.	D1	D2	D3	L	L 1	G	Weight (kg)
12	ST12-SFH3-120	3	8	12	120	19	-	
	ST12-SFH4-120	4	8	12	120	22	-	
	ST12-SFH5-120	5	10	12	120	28	-	
	ST12-SFH6-120	6	10	12	120	36	M5×0.8	
16	ST16-SFH3-120	3	10	16	120	19	-	
	ST16-SFH4-120	4	10	16	120	22	-	
	ST16-SFH5-120	5	10	16	120	28	-	
	ST16-SFH6-120	6	10	16	120	36	M5×0.8	
20	ST16-SFH8-120	8	12	16	120	36	M6×1.0	
	ST20-SFH3-120	3	10	20	120	19	-	
	ST20-SFH4-120	4	10	20	120	22	-	
	ST20-SFH5-120	5	10	20	120	28	-	
	ST20-SFH6-120	6	10	20	120	36	M5×0.8	
	ST20-SFH8-120	8	12	20	120	36	M6×1.0	
	ST20-SFH10-120	10	14	20	120	42	M8×1.0	
	ST20-SFH12-120	12	16	20	120	47	M10×1.0	

► Notice when ordering – Please inform us whether it is for shrink fit holder or for ordinary holder.

SHRINK FIT HOLDER SCHRUMPFUTTER

 TOOL
HOLDERS

EXTENSION (VERLÄNGERUNG)

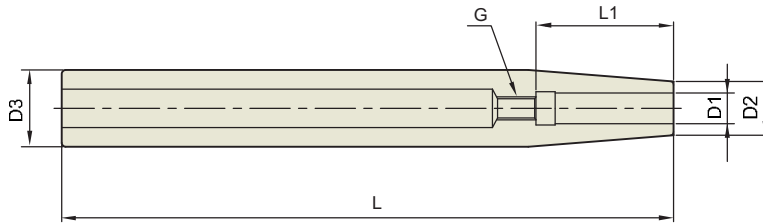

EXT.

 Taper
Accuracy
AT3

G Value

RPM

 Coolant
System

■ EXTENDED

TAPER No.	CODE No.	D1	D2	D3	L	L 1	G	Weight (kg)
12	ST12-SFH3-160	3	8	12	160	19	-	
	ST12-SFH4-160	4	8	12	160	22	-	
	ST12-SFH5-160	5	10	12	160	28	-	
	ST12-SFH6-160	6	10	12	160	36	M5×0.8	
16	ST16-SFH3-160	3	10	16	160	19	-	
	ST16-SFH4-160	4	10	16	160	22	-	
	ST16-SFH5-160	5	10	16	160	28	-	
	ST16-SFH6-160	6	10	16	160	36	M5×0.8	
20	ST16-SFH8-160	8	12	16	160	36	M6×1.0	
	ST20-SFH3-160	3	10	20	160	19	-	
	ST20-SFH4-160	4	10	20	160	22	-	
	ST20-SFH5-160	5	10	20	160	28	-	
	ST20-SFH6-160	6	10	20	160	36	M5×0.8	
	ST20-SFH8-160	8	12	20	160	36	M6×1.0	
25	ST20-SFH10-160	10	14	20	160	42	M8×1.0	
	ST20-SFH12-160	12	16	20	160	47	M10×1.0	
	ST25-SFH3-160	3	10	25	160	19	-	
	ST25-SFH4-160	4	10	25	160	22	-	
	ST25-SFH5-160	5	15	25	160	28	-	
	ST25-SFH6-160	6	20	25	160	36	M5×0.8	
	ST25-SFH8-160	8	20	25	160	36	M6×1.0	
	ST25-SFH10-160	10	20	25	160	42	M8×1.0	
32	ST25-SFH12-160	12	20	25	160	47	M10×1.0	
	ST25-SFH14-160	14	20	25	160	47	M10×1.0	
	ST25-SFH16-160	16	22	25	160	50	M12×1.0	
	ST32-SFH6-160	6	20	32	160	36	M5×0.8	
	ST32-SFH8-160	8	20	32	160	36	M6×1.0	
	ST32-SFH10-160	10	24	32	160	42	M8×1.0	
	ST32-SFH12-160	12	24	32	160	47	M10×1.0	
	ST32-SFH14-160	14	27	32	160	47	M10×1.0	
32	ST32-SFH16-160	16	27	32	160	50	M12×1.0	
	ST32-SFH18-160	18	27	32	160	50	M12×1.0	
	ST32-SFH20-160	20	27	32	160	52	M16×1.0	

► Notice when ordering – Please inform us whether it is for shrink fit holder or for ordinary holder.

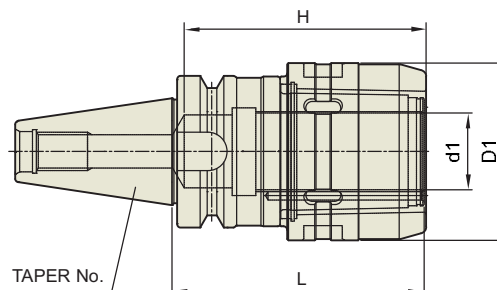
**TOOL
HOLDERS**
HIGH SPEED MILLING CHUCK
HOCHGESCHWINDIGKEITS FRÄSERFUTTER
MAS403-BT FORM AD

MAS403 -BT	Taper Accuracy AT3	G Value 6.3	RPM 20,000	Coolant System
---------------	--------------------------	----------------	---------------	-------------------

TAPER No.	CODE No.	d1	D1	L	H	Weight (kg)
30	BT30-C20-75HS	20	54	75	70	1.50
	BT30-C25-80HS	25	62.5	80	80	2.00
40	BT40-C20-80HS	20	54	80	70	2.00
	BT40-C20-105HS	20	54	105	70	2.10
	BT40-C25-105HS	25	62.5	105	80	2.50
	BT40-C32-90HS	32	74	90	100	3.00
	BT40-C32-105HS	32	74	105	100	3.10
	BT40-C32-135HS	32	74	135	100	3.30
50	BT50-C20-105HS	20	54	105	70	4.50
	BT50-C20-135HS	20	54	135	70	4.90
	BT50-C20-165HS	20	54	165	70	5.40
	BT50-C25-105HS	25	62.5	105	80	5.20
	BT50-C25-135HS	25	62.5	135	80	5.80
	BT50-C25-165HS	25	62.5	165	80	6.20
	BT50-C32-105HS	32	74	105	100	6.00
	BT50-C32-135HS	32	74	135	100	6.70
	BT50-C32-165HS	32	74	165	100	7.40
	BT50-C42-115HS	42	92	115	110	6.70
	BT50-C42-135HS	42	92	135	110	7.60
BT50-C42-165HS	42	92	165	110	8.30	



**MILLING CHUCK
FRÄSERSPANNFUTTER**

TOOL
HOLDERS

MAS403-BT

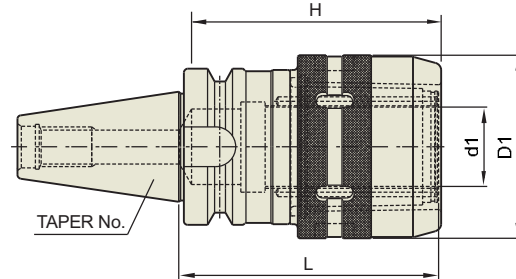

MAS403 -BT	Taper Accuracy AT3	G Value	RPM	Coolant System
---------------	--------------------------	---------	-----	-------------------

TAPER No.	CODE No.	d1	D1	L	H	Applicable collet	Weight (kg)
30	BT30-C20- 75	20	54	75	70	K20, CK20	1.5
	BT30-C25- 80	25	62.5	80	80	K25, CK25	2.0
40	BT40-C20- 80	20	54	80	70	K20, CK20	2.0
	BT40-C20-105	20	54	105	70	K20, CK20	2.1
	BT40-C25-105	25	62.5	105	80	K25, CK25	2.5
	BT40-C32- 90	32	72	90	100	K32, CK32	3
	BT40-C32-105	32	72	105	100	K32, CK32	3.1
	BT40-C32-135	32	72	135	100	K32, CK32	3.3
50	BT50-C20-105	20	54	105	70	K20, CK20	4.5
	BT50-C20-135	20	54	135	70	K20, CK20	4.9
	BT50-C20-165	20	54	165	70	K20, CK20	5.4
	BT50-C25-105	25	62.5	105	80	K25, CK25	5.2
	BT50-C25-135	25	62.5	135	80	K25, CK25	5.8
	BT50-C25-165	25	62.5	165	80	K25, CK25	6.2
	BT50-C32-105	32	72	105	100	K32, CK32	6
	BT50-C32-115	32	72	115	100	K32, CK32	6.2
	BT50-C32-135	32	72	135	100	K32, CK32	6.7
	BT50-C32-165	32	72	165	100	K32, CK32	7.4
	BT50-C42-115	42	92	115	110	K42, CK42	6.7
	BT50-C42-135	42	92	135	110	K42, CK42	7.6
BT50-C42-165	42	92	165	110	K42, CK42	8.3	

SPARE PARTS

END MILL COLLET	CODE No.	SET
	K20 - 6, 8, 10, 12, 16	5PCS
	K25 - 6, 8, 10, 12, 16, 20	6PCS
	K32 - 6, 8, 10, 12, 16, 20, 25	7PCS
	K42 - 6, 8, 10, 12, 16, 20, 25, 32	8PCS
END MILL COLLET	CODE No.	SET
	CK20 - 6, 8, 10, 12, 16	5PCS
	CK25 - 6, 8, 10, 12, 16, 20	6PCS
	CK32 - 6, 8, 10, 12, 16, 20, 25	7PCS
	CK42 - 6, 8, 10, 12, 16, 20, 25, 32	8PCS
SPANNER	CODE No.	
	C20 SP	
	C25 SP	
	C32 SP	
	C42 SP	

HIGH SPEED MILLING CHUCK
HOCHGESCHWINDIGKEITS FRÄSERFUTTER

DIN69893-HSK FORM A

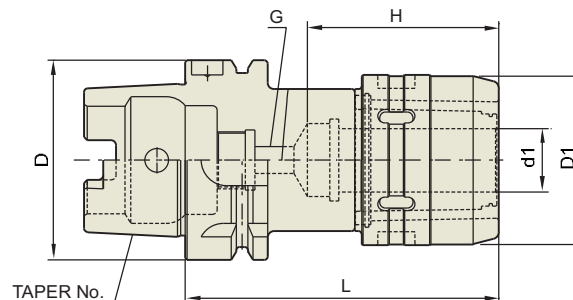

DIN69893 - HSK	Taper Accuracy AT3	G Value 6.3	RPM 20,000	Coolant System
-------------------	--------------------------	----------------	---------------	-------------------

TAPER No.	CODE No.	d1	D1	L	H	Weight (kg)
50A	HSK50A-C20-100HS	20	54	100	70	1.30
	HSK63A-C20-105HS	20	54	105	70	1.50
63A	HSK63A-C25-120HS	25	62.5	120	80	2.20
	HSK63A-C32-130HS	32	74	130	100	2.70
100A	HSK100A-C20-110HS	20	54	110	70	3.50
	HSK100A-C25-130HS	25	62.5	130	80	3.80
	HSK100A-C32-135HS	32	74	135	100	4.20
	HSK100A-C42-135HS	42	74	135	100	5.30



**MILLING CHUCK
FRÄSERSPANNFUTTER**

TOOL
HOLDERS

HSK FORM A

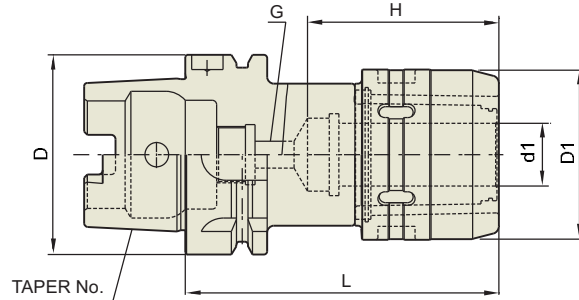

DIN69893
- HSK

Taper
Accuracy
AT3

G Value

RPM

Coolant
System

TAPER No.	CODE No.	D	d1	D1	L	H	G	Weight (kg)
50A	HSK 50A-C20-100	50	20	54	100	70	M12	1.30
63A	HSK 63A-C20-105	63	20	54	105	70	M12	1.50
	HSK 63A-C32-130	63	32	72	130	100	M12	2.70
100A	HSK100A-C20-110	100	20	54	110	70	M12	3.50
	HSK100A-C32-135	100	32	72	135	100	M12	4.20
	HSK100A-C42-135	100	42	92	135	100	M12	5.30

SPARE PARTS

END MILL COLLET	CODE No.	SET
	K20 - 6, 8, 10, 12, 16	5PCS
	K32 - 6, 8, 10, 12, 16, 20, 25	7PCS
	K42 - 6, 8, 10, 12, 16, 20, 25, 32	8PCS
END MILL COLLET	CODE No.	SET
	CK20 - 6, 8, 10, 12, 16	5PCS
	CK25 - 6, 8, 10, 12, 16, 20	6PCS
	CK32 - 6, 8, 10, 12, 16, 20, 25	7PCS
	CK42 - 6, 8, 10, 12, 16, 20, 25, 32	8PCS
SPANNER	CODE No.	
	C20 SP	
	C25 SP	
	C32 SP	
	C42 SP	

HIGH SPEED MILLING CHUCK
HOCHGESCHWINDIGKEITS FRÄSERFUTTER

DIN 69871-SK FORM AD

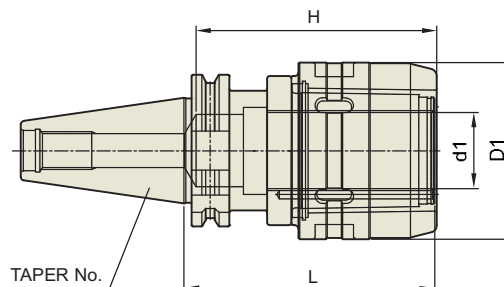

DIN69871 -SK	Taper Accuracy AT3	G Value 6.3	RPM 20,000	Coolant System
-----------------	--------------------------	----------------	---------------	-------------------

TAPER No.	CODE No.	d1	D1	L	H	Weight (kg)
30	SK30-C20-80HS	20	54	80	70	1.15
	SK30-C25-80HS	25	62.5	80	80	1.48
40	SK40-C20-105HS	20	54	105	70	1.77
	SK40-C25-105HS	25	62.5	105	80	2.10
	SK40-C32-105HS	32	74	105	100	2.40
	SK40-C32-135HS	32	74	135	100	3.10
50	SK50-C20-105HS	20	54	105	70	3.40
	SK50-C25-105HS	25	62.5	105	80	3.80
	SK50-C32-105HS	32	74	105	100	4.30
	SK50-C32-135HS	32	74	135	100	4.90
	SK50-C32-165HS	32	74	165	100	5.60
	SK50-C42-115HS	42	92	115	110	4.60
	SK50-C42-135HS	42	92	135	110	5.60
	SK50-C42-165HS	42	92	165	110	6.10

**MILLING CHUCK
FRÄSERSPANNFUTTER**

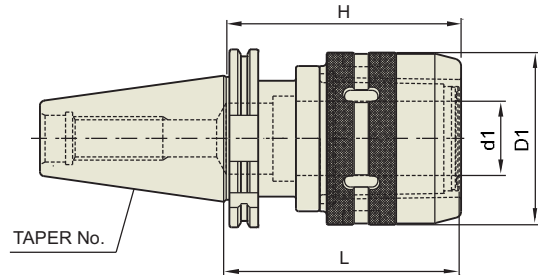
 TOOL
HOLDERS

 DIN69871
-SK

 Taper
Accuracy
AT3

G Value

RPM

 Coolant
System

STUB

TAPER No.	CODE No.	d1	D1	L	H	Weight (kg)
30	SK30-C20-80	20	54	80	70	1.15
	SK30-C25-80	25	62.5	80	80	1.48
40	SK40-C20-90	20	54	90	70	1.60
	SK40-C32-90	32	72	90	100	2.00
50	SK50-C20-80	20	54	80	70	3.22
	SK50-C25-90	25	62.5	90	80	3.61
	SK50-C32-90	32	72	90	100	3.87

STANDARD

TAPER No.	CODE No.	d1	D1	L	H	Weight (kg)
40	SK40-C20-105	20	54	105	70	1.77
	SK40-C25-105	25	62.5	105	80	2.01
	SK40-C32-105	32	72	105	100	2.42
50	SK50-C20-105	20	54	105	70	3.39
	SK50-C25-105	25	62.5	105	80	3.78
	SK50-C32-105	32	72	105	100	4.31
	SK50-C42-115	42	92	115	110	4.53

EXTENDED

TAPER No.	CODE No.	d1	D1	L	H	Weight (kg)
40	SK40-C32-135	32	72	135	100	3.11
50	SK50-C32-135	32	72	135	100	4.94
	SK50-C42-135	42	92	135	110	5.62

EXTRA EXTENDED

TAPER No.	CODE No.	d1	D1	L	H	Weight (kg)
50	SK50-C32-165	32	72	165	100	5.59
	SK50-C42-165	42	92	165	110	6.10

MILLING CHUCK FRÄSERSPANNFUTTER

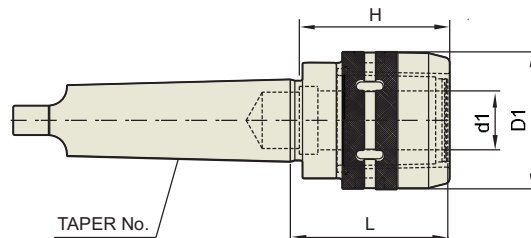

DIN 228 - MTA	Taper Accuracy AT3	G Value	RPM	Coolant System
------------------	-----------------------	---------	-----	----------------

TAPER No.	CODE No.	d1	D1	L	H	Applicable collet	Weight (kg)
MT4	MTA4-C32	32	72	98	100	K32, CK32	2.57
MT5	MTA5-C32	32	72	85	100	K32, CK32	3.06
	MTA5-C42	42	92	114	110	K42, CK42	3.45
MT6	MTA6-C42	42	92	99	110	K42, CK42	4.14

► In case of MT16, please inform us of machine model number and company name for selection of cutter groove.

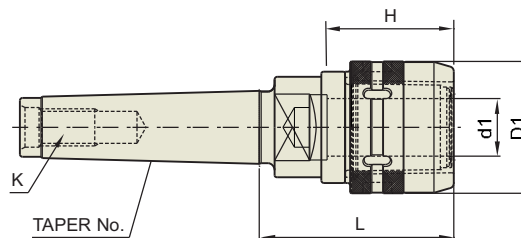

DIN 228 - MTB	Taper Accuracy AT3	G Value	RPM	Coolant System
------------------	-----------------------	---------	-----	----------------

TAPER No.	CODE No.	d1	D1	L	H	K	Applicable collet	Weight (kg)
MT3	MTB3-C20	20	54	74	70	M12	K20, CK20	2.10
MT4	MTB4-C32	32	72	98	100	M16	K32, CK32	2.57
	MTB5-C32	32	72	85	100	M20	K32, CK32	3.06
MT5	MTB5-C42	42	92	114	110	M20	K42, CK42	3.45



**MILLING CHUCK
FRÄSERSPANNFUTTER**

TOOL
HOLDERS

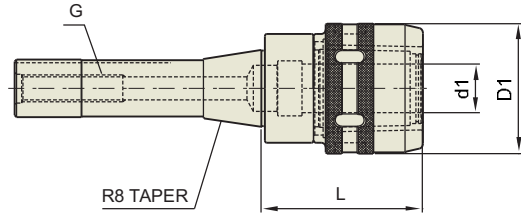

R8	Taper Accuracy AT3	G Value	RPM	Coolant System
----	-----------------------	---------	-----	----------------

TAPER No.	CODE No.	d1	D1	L	G	Applicable collet	Weight (kg)
R8	R8-C20	20	54	69	U7/16-20	K20, CK20	1.40

**MILLING CHUCK STANDARD SET
GEGENSTUCK FUR FRASERSPANNFUTTER**

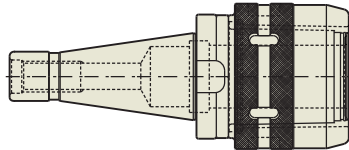

MACHINE SPINDLE TAPER	STANDARD SET CODE No.	MILLING CHUCK	END MILL COLLET	MORSE TAPER COLLET	DRILL CHUCK BAR
R8	SR8-C20	R8-C20	K20-(6-16)(5PCS)	K20-MT1,2	K20-JTA6
NT30	SNT30-20	NT30-C20	K20-(6-16)(5PCS)	K20-MT1,2	K20-JTA6
NT40	SNT40-32A	NT40-C32	K32-(6-25)(7PCS)	—	—
	SNT40-32	NT40-C32	K32-(6-25)(7PCS)	K32-MT1,2,3	K32-JTA6
NT50	SNT50-32A	NT50-C32	K32-(6-25)(7PCS)	—	K32-JTA6
	SNT50-32	NT50-C32	K32-(6-25)(7PCS)	K32-MT1,2,3	K32-JTA6
	SNT50-42A	NT50-C42	K42-(6-32)(8PCS)	—	—
	SNT50-42	NT50-C42	K42-(6-32)(8PCS)	K42-MT1,2,3,4	K42-JTA6

MILLING CHUCK

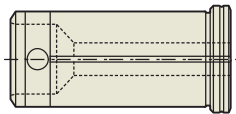
CODE No.
NT30 - C20
NT40 - C32
NT50 - C32
NT50 - C42

END MILL COLLET

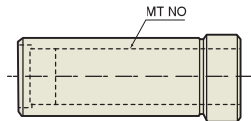
CODE No.	SET
K20 - 6, 8, 10, 12, 16	5PCS
K25 - 6, 8, 10, 12, 16, 20	6PCS
K32 - 6, 8, 10, 12, 16, 20, 25	7PCS
K42 - 6, 8, 10, 12, 16, 20, 25, 32	8PCS

MT COLLET

CODE No.
K20 - MT1, 2
K25 - MT1, 2, 3
K32 - MT1, 2, 3
K42 - MT1, 2, 3, 4

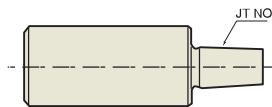
DRILL CHUCK ARBOR

CODE No.
K20 - JTA6
K25 - JTA6
K32 - JTA6
K42 - JTA6

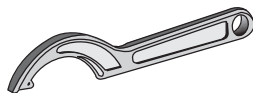
SPANNER

CODE No.
C20 SP
C25 SP
C32 SP
C42 SP



Q.C MILLING CHUCK SET

SCHNELLWECHSEL GEGENSTUCK FÜR FRASERSPANNFUTTER



MACHINE SPINDLE TAPER	Q.C MILLING HOLDER SET CODE No.	Q.C MASTER HOLDER	Q.C MILLING CHUCK	END MILL COLLETS	Q.C FACE MILL ARBOR	Q.C DRILL CHUCK BAR	DRILL CHUCK ARBOR	Q.C TAPER SLEEVE
NT40	SMH40-T35-32 A	MH40-T35	QT35-32	K32-(6-25)(7PCS)	QT35-4R	—	K32-J6	—
	SMH40-T35-32 B	MH40-T35	QT35-32	K32-(6-25)(7PCS)	QT35-4R	QT35-J6	—	QT35-MT2,3,4
NT50	SMH50-T45-32 A	MH50-T45	QT45-32	K32-(6-25)(7PCS)	QT45-5R	—	K32-J6	—
	SMH50-T45-32 B	MH50-T45	QT45-32	K32-(6-25)(7PCS)	QT45-5R	QT45-J6	—	QT45-MT2,3,4
	SMH50-T45-42 A	MH50-T45	QT45-42	K42-(6-32)(8PCS)	QT45-5R	—	K42-J6	—
	SMH50-T45-42 B	MH50-T45	QT45-42	K42-(6-32)(8PCS)	QT45-5R	QT45-J6	—	QT45-MT2,3,4

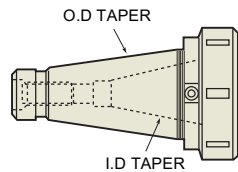

Q.C MASTER HOLDER

CODE No.	O.D TAPER	I.D TAPER	DRAW THREADS
MH40-T35	NT40	NT35	U5/8-11(M16-2)
MH50-T45	NT50	NT45	U1-8(M24-3)

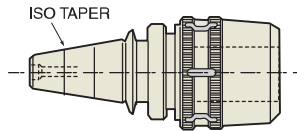

Q.C MILLING CHUCK

CODE No.	Q.C MASTER HOLDER
QT35-C32	MH40
QT45-C32	MH50
QT45-C42	MH50

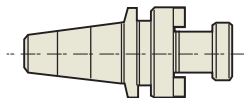

Q.C FACE MILL ARBOR

CODE No.	Q.C MASTER HOLDER
QT35-3,4,5R	MH40
QT45-3,4,5,6R	MH50

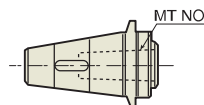

Q.C TAPER SLEEVE

CODE No.	Q.C MASTER HOLDER
QT35 - MT1, 2, 3	MH40
QT45 - MT1, 2, 3, 4	MH50

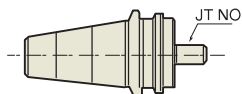

Q.C DRILL CHUCK ARBOR

CODE No.	Q.C MASTER HOLDER	DRILL Ø
QT35-J6	MH40	1-13mm
QT45-J6	MH50	1-13mm

COLLET & SPANNER
SPANNZANGE UND MAULSCHLÜSSEL

END MILL COLLET (K TYPE)
SPANNZANGEN

CODE No.	SET
K20-6,8,10,12,16	5pcs
K25-6,8,10,12,16,20	6pcs
K32-6,8,10,12,16,20,25	7pcs
K42-6,8,10,12,16,20,25,32	8pcs

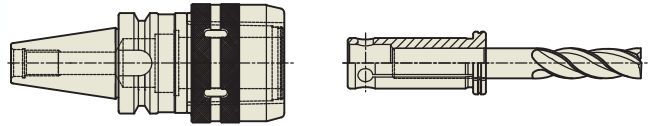
END MILL COLLET (CK TYPE)
SPANNZANGEN MIT VERSTELLSCHRAUBE

CODE No.	SET
CK20-6,8,10,12,16	5pcs
CK25-6,8,10,12,16,20	6pcs
CK32-6,8,10,12,16,20,25	7pcs
CK42-6,8,10,12,16,20,25,32	8pcs

MT COLLET

CODE No.
K20-MT1,2
K25-MT1,2
K32-MT1,2,3
K42-MT1,2,3,4

DRILL CHUCK ARBOR

CODE No.
K20-JTA6
K25-JTA6
K32-JTA6
K42-JTA6

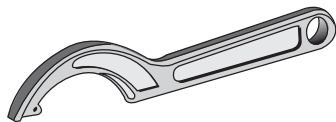
SPANNER
MAULSCHLÜSSEL

CODE No.
C20 SP
C25 SP
C32 SP
C42 SP



SK SLIM CHUCK
SK SCHLANKE FUTTER

TOOL
HOLDERS

MAS403-BT

- ▶ Realizing highest precision .
- ▶ Applicable to various tools such as end mill, drill, reamer, tap, and etc.
- ▶ Usable for long hours with use of nut produced by Switzerland manufacturer
- ▶ Creating maximum effect with slim type when machining deep shape

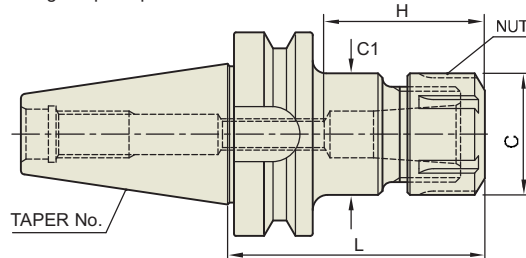

MAS403-BT	Taper Accuracy AT3	G Value 6.3	RPM 12,000	Coolant System
-----------	-----------------------	----------------	---------------	----------------

TAPER No.	CODE No.	RANGE	L	C	C1	H		COLLET	Weight (kg)
						Min	Max		
30	BT30-SKA06-60	0.9-6.0	60	20	19.5	21	35	SKC6	0.7
	BT30-SKA06-90	0.9-6.0	90	20	19.5	21	35	SKC6	0.8
	BT30-SKA10-60	1.75-10.0	60	28	27.5	30	50	SKC10	0.9
	BT30-SKA10-90	1.75-10.0	90	28	27.5	30	50	SKC10	1
	BT30-SKA13-60	2.75-13.0	60	33	33	31	65	SKC13	1
	BT30-SKA13-90	2.75-13.0	90	33	33	31	65	SKC13	1.1
	BT30-SKA16-60	2.75-16.0	60	40	40	45	60	SKC16	1.1
	BT30-SKA16-90	2.75-16.0	90	40	40	45	60	SKC16	1.2
	BT30-SKA20-60	4.0-20.0	60	48.5	48.5	65	75	SKC20	1.3
	BT30-SKA20-90	4.0-20.0	90	48.5	48.5	65	75	SKC20	1.4
40	BT40-SKA06-90	0.9-6.0	90	20	19.5	21	35	SKC6	1.1
	BT40-SKA06-120	0.9-6.0	120	20	19.5	21	35	SKC6	1.4
	BT40-SKA06-150	0.9-6.0	150	20	19.5	21	35	SKC6	1.5
	BT40-SKA10-90	1.75-10.0	90	28	27.5	30	50	SKC10	1.2
	BT40-SKA10-120	1.75-10.0	120	28	27.5	30	50	SKC10	1.4
	BT40-SKA10-150	1.75-10.0	150	28	27.5	30	50	SKC10	1.6
	BT40-SKA13-90	2.75-13.0	90	33	33	31	65	SKC13	1.4
	BT40-SKA13-120	2.75-13.0	120	33	33	31	65	SKC13	1.6
	BT40-SKA13-150	2.75-13.0	150	33	40	31	65	SKC13	1.8
	BT40-SKA16-90	2.75-16.0	90	40	40	45	70	SKC16	1.5
	BT40-SKA16-120	2.75-16.0	120	40	40	45	70	SKC16	1.7
	BT40-SKA16-150	2.75-16.0	150	40	40	45	70	SKC16	1.9
	BT40-SKA20-90	4.0-20.0	90	48.5	48.5	47	80	SKC20	1.6
	BT40-SKA20-120	4.0-20.0	120	48.5	48.5	47	80	SKC20	2
	BT40-SKA20-150	4.0-20.0	150	48.5	48.5	47	80	SKC20	2.4
	BT40-SKA25-90	16.0-25.4	90	55	55	55	85	SKC25	1.8
	BT40-SKA25-120	16.0-25.4	120	55	55	55	85	SKC25	2
BT40-SKA25-150	16.0-25.4	150	55	55	55	85	SKC25	2.3	

- ▶ For usable SK collet, please refer to page 1103 and 1104.
- ▶ Higher balancing grade product could be supplied by customer's request.

SK SLIM CHUCK SK SCHLANKE FUTTER

MAS403-BT

- ▶ Realizing highest precision .
- ▶ Applicable to various tools such as end mill, drill, reamer, tap, and etc.
- ▶ Usable for long hours with use of nut produced by Switzerland manufacturer
- ▶ Creating maximum effect with slim type when machining deep shape

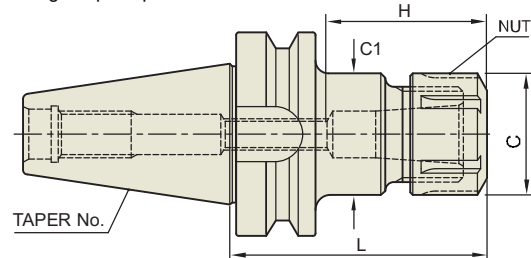

MAS403 -BT	Taper Accuracy AT3	G Value 6.3	RPM 12,000	Coolant System
---------------	--------------------------	----------------	---------------	-------------------

TAPER No.	CODE No.	RANGE	L	C	C1	H		COLLET	Weight (kg)
						Min	Max		
50	BT50-SKA06-105	0.9-6.0	105	20	19.5	21	35	SKC6	3.8
	BT50-SKA06-135	0.9-6.0	135	20	19.5	21	35	SKC6	3.9
	BT50-SKA06-165	0.9-6.0	165	20	32.5	21	35	SKC6	4
	BT50-SKA06-195	0.9-6.0	195	20	32.5	21	35	SKC6	4.2
	BT50-SKA10-105	1.75-10.0	105	28	27.5	30	50	SKC10	4.2
	BT50-SKA10-135	1.75-10.0	135	28	27.5	30	50	SKC10	4.4
	BT50-SKA10-165	1.75-10.0	165	28	37.4	30	50	SKC10	4.6
	BT50-SKA10-195	1.75-10.0	195	28	37.4	30	50	SKC10	4.8
	BT50-SKA13-105	2.75-13.0	105	33	33	31	65	SKC13	4.5
	BT50-SKA13-135	2.75-13.0	135	33	33	31	65	SKC13	4.7
	BT50-SKA13-165	2.75-13.0	165	33	45	31	65	SKC13	4.9
	BT50-SKA13-195	2.75-13.0	195	33	45	31	65	SKC13	5.2
	BT50-SKA16-105	2.75-16.0	105	40	40	45	70	SKC16	4.7
	BT50-SKA16-135	2.75-16.0	135	40	40	45	70	SKC16	4.9
	BT50-SKA16-165	2.75-16.0	165	40	40	45	70	SKC16	5.1
	BT50-SKA16-195	2.75-16.0	195	40	40	45	70	SKC16	5.5
	BT50-SKA20-105	4.0-20.0	105	48.5	48.5	47	80	SKC20	4.3
	BT50-SKA20-135	4.0-20.0	135	48.5	48.5	47	80	SKC20	4.6
	BT50-SKA20-165	4.0-20.0	165	48.5	48.5	47	80	SKC20	5
	BT50-SKA20-195	4.0-20.0	195	48.5	48.5	47	80	SKC20	5.4
BT50-SKA25-105	16.0-25.4	105	55	55	55	85	SKC25	5.2	
BT50-SKA25-135	16.0-25.4	135	55	55	55	85	SKC25	5.4	
BT50-SKA25-165	16.0-25.4	165	55	55	55	85	SKC25	5.6	
BT50-SKA25-195	16.0-25.4	195	55	55	55	85	SKC25	6	

- ▶ For usable SK collet, please refer to page 1103 and 1104.
- ▶ Higher balancing grade product could be supplied by customer's request.



SK SLIM CHUCK SK SCHLANKE FUTTER

DIN 69893-HSK FORM A

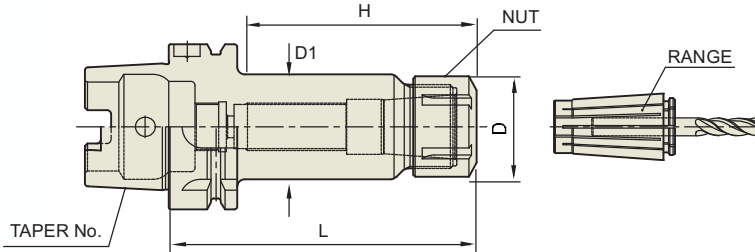

DIN69893
- HSK

Taper
Accuracy
AT3

G Value
6.3

RPM
12,000

Coolant
System

TAPER No.	CODE No.	RANGE	D	D1	L	H		COLLET	Weight (kg)
						Min	Max		
HSK 50	HSK50A-SKA06-80	0.75 - 6.0	20	19.5	80	21	35	SKC06	0.9
	HSK50A-SKA10-100	1.75 - 10.0	28	27.5	100	30	50	SKC10	1.1
	HSK50A-SKA13-100	2.75-13.0	33	33	100	31	65	SKC13	1.2
HSK 63	HSK63A-SKA06-100	0.75 - 6.0	20	19.5	100	21	35	SKC06	1.4
	HSK63A-SKA10-100	1.75 - 10.0	28	27.5	100	30	50	SKC10	1.6
	HSK63A-SKA13-100	2.75-13.0	33	33	100	31	65	SKC13	1.7
	HSK63A-SKA16-120	2.75 - 16.0	40	40	120	45	70	SKC16	1.7
	HSK63A-SKA20-120	4.0-20.0	48.5	48.5	120	65	75	SKC20	2.1
	HSK63A-SKA25-150	16.0 - 25.4	55	55	150	55	85	SKC25	2.4
HSK 100	HSK100A-SKA06-120	0.75 - 6.0	20	19.5	120	21	35	SKC06	4
	HSK100A-SKA10-150	1.75 - 10.0	28	27.5	150	30	50	SKC10	4.5
	HSK100A-SKA13-150	2.75-13.0	33	40	150	31	65	SKC13	4.6
	HSK100A-SKA16-150	2.75 - 16.0	40	40	150	45	70	SKC16	5.1
	HSK100A-SKA20-150	4.0-20.0	48.5	48.5	150	65	75	SKC20	5.4
	HSK100A-SKA25-160	16.0 - 25.4	55	55	160	55	85	SKC25	5.5

- ▶ For usable SK collet, please refer to page 1103 and 1104.
- ▶ Higher balancing grade product could be supplied by customer's request.

SK SLIM CHUCK - STRAIGHT SHANK SK SCHLANKE FUTTER -- GERADEAUS SCHAFT

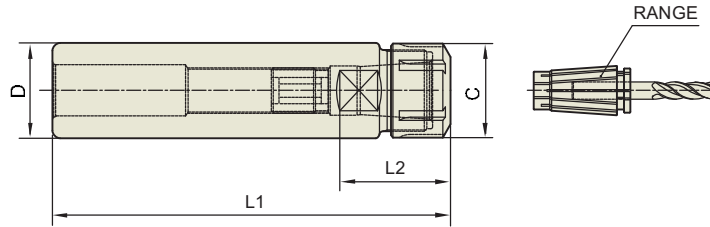

K	Taper Accuracy AT3	G Value	RPM	Coolant System
---	-----------------------	---------	-----	----------------

TAPER No.	CODE No.	RANGE	D	C	L1	L2	COLLET	Weight (kg)
K20	K20-SKA06-100	0.75 - 6.0	20	28	100	21 - 35	SKC06	0.2
	K20-SKA06-140	0.75 - 6.0	20	28	140	21 - 35	SKC06	0.3
	K20-SKA10-100	1.75 - 10.0	28	28	100	30 - 50	SKC10	0.2
	K20-SKA10-140	1.75 - 10.0	28	28	140	30 - 50	SKC10	0.3
K25	K25-SKA06-100	0.75 - 6.0	20	28	100	21 - 35	SKC06	0.3
	K25-SKA06-140	0.75 - 6.0	20	28	140	21 - 35	SKC06	0.5
	K25-SKA10-100	1.75 - 10.0	28	28	100	30 - 50	SKC10	0.3
	K25-SKA10-150	1.75 - 10.0	28	28	150	30 - 50	SKC10	0.5
	K25-SKA13-100	2.75-13.0	33	37	100	31 - 65	SKC13	0.4
	K25-SKA13-150	2.75-13.0	33	37	150	31 - 65	SKC13	0.6
K32	K32-SKA10-100	1.75 - 10.0	28	28	100	30 - 50	SKC10	0.5
	K32-SKA10-150	1.75 - 10.0	28	28	150	30 - 50	SKC10	0.7
	K32-SKA13-100	2.75-13.0	33	37	100	31 - 65	SKC13	1
	K32-SKA13-150	2.75-13.0	33	37	150	31 - 65	SKC13	1.2
	K32-SKA16-100	2.75 - 16.0	40	47	100	40 - 70	SKC16	1
	K32-SKA16-150	2.75 - 16.0	40	47	150	40 - 70	SKC16	1.2
	K32-SKA20-100	4.0-20.0	48.5	47	100	47 - 80	SKC20	1.1
	K32-SKA20-150	4.0-20.0	48.5	47	150	47 - 80	SKC20	1.3
	K32-SKA25-150	16.0 - 25.4	55	47	150	50 - 85	SKC25	1.3

► For usable SK collet, please refer to page 1103 and 1104.

**SK SLIM CHUCK COLLET**
SK SCHLANKE FUTTER SPANNZANGETOOL
HOLDERS

- ▶ Ensuring strong chucking power of 8° Taper and high precision
- ▶ Able to use various tools ranging from 0.9 to 25.4mm dia.
- ▶ Applicable to various tools such as end mill, drill, tap, reamer
- ▶ Collet of 3_{µm} or 5_{µm} T.I.R at 3D available by customer's request

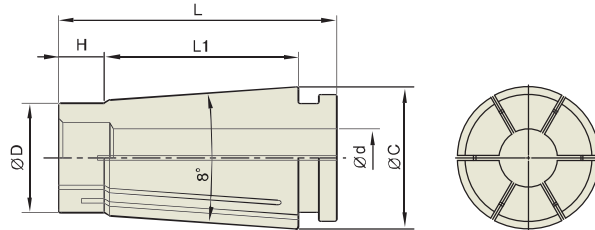

Style	Code No.	Chucking (d)	Style	Code No.	Chucking (d)	Style	Code No.	Chucking (d)
SKC 6	SKC 6 - 1	0.9 - 1.0	SKC 10	SKC10 - 2	1.75 - 2.0	SKC 13	SKC 13 - 3	2.75 - 3.0
	SKC 6 - 1.5	1.3 - 1.5		SKC10 - 2.5	2.25 - 2.5		SKC 13 - 3.5	3.0 - 3.5
	SKC 6 - 2	1.8 - 2.0		SKC10 - 3	2.75 - 3.0		SKC 13 - 4	3.5 - 4.0
	SKC 6 - 2.5	2.3 - 2.5		SKC10 - 3.5	3.0 - 3.5		SKC 13 - 4.5	4.0 - 4.5
	SKC 6 - 3	2.8 - 3.0		SKC10 - 4	3.5 - 4.0		SKC 13 - 5	4.5 - 5.0
	SKC 6 - 3.5	3.0 - 3.5		SKC10 - 4.5	4.0 - 4.5		SKC 13 - 5.5	5.0 - 5.5
	SKC 6 - 4	3.5 - 4.0		SKC10 - 5	4.5 - 5.0		SKC 13 - 6	5.5 - 6.0
	SKC 6 - 4.5	4.0 - 4.5		SKC10 - 5.5	5.0 - 5.5		SKC 13 - 6.5	6.0 - 6.5
	SKC 6 - 5	4.5 - 5.0		SKC10 - 6	5.5 - 6.0		SKC 13 - 7	6.5 - 7.0
	SKC 6 - 5.5	5.0 - 5.5		SKC10 - 6.5	6.0 - 6.5		SKC 13 - 7.5	7.0 - 7.5
SKC 6 - 6	5.5 - 6.0	SKC10 - 7	6.5 - 7.0	SKC 13 - 8	7.5 - 8.0			
		SKC10 - 7.5	7.0 - 7.5	SKC 13 - 8.5	8.0 - 8.5			
		SKC10 - 8	7.5 - 8.0	SKC 13 - 9	8.5 - 9.0			
		SKC10 - 8.5	8.0 - 8.5	SKC 13 - 9.5	9.0 - 9.5			
		SKC10 - 9	8.5 - 9.0	SKC 13 - 10	9.5 - 10.0			
		SKC10 - 9.5	9.0 - 9.5	SKC 13 - 10.5	10.0 - 10.5			
		SKC10 - 10	9.5 - 10.0	SKC 13 - 11	10.5 - 11.0			
				SKC 13 - 11.5	11.0 - 11.5			
				SKC 13 - 12	11.5 - 12.0			
				SKC 13 - 12.5	12.0 - 12.5			
				SKC 13 - 13	12.5 - 13.0			

SKC COLLET DIMENSION

STYLE	D	L	L1	H	C	Weight (kg)
SKC 6	7.5	25.7	17.6	3.8	10	0.03
SKC 10	12	32	21.3	5	15	0.04
SKC 13	15.4	39	28.3	5.5	20	
SKC 16	18.8	46	32	8	24	0.06
SKC 20	22.5	54.2	41	8	29	
SKC 25	28.9	58.2	43	8.5	35	0.10

SK SLIM CHUCK COLLET SK SCHLANKE FUTTER SPANNZANGE

- ▶ Ensuring strong chucking power of 8° Taper and high precision
- ▶ Able to use various tools ranging from 0.9 to 25.4mm dia.
- ▶ Applicable to various tools such as end mill, drill, tap, reamer
- ▶ Collet of 3 μ m or 5 μ m T.I.R at 3D available by customer's request

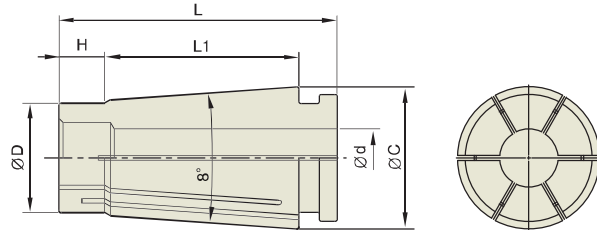

Style	Code No.	Chucking (d)	Style	Code No.	Chucking (d)	Style	Code No.	Chucking (d)
SKC 16	SKC16 - 3	2.75 - 3.0	SKC 20	SKC 20 - 4	3.5 - 4.0	SKC 25	SKC25 - 16.5	16.0 - 16.5
	SKC16 - 3.5	3.0 - 3.5		SKC 20 - 4.5	4.0 - 4.5		SKC25 - 17	16.5 - 17.0
	SKC16 - 4	3.5 - 4.0		SKC 20 - 5	4.5 - 5.0		SKC25 - 17.5	17.0 - 17.5
	SKC16 - 4.5	4.0 - 4.5		SKC 20 - 5.5	5.0 - 5.5		SKC25 - 18	17.5 - 18.0
	SKC16 - 5	4.5 - 5.0		SKC 20 - 6	5.5 - 6.0		SKC25 - 18.5	18.0 - 18.5
	SKC16 - 5.5	5.0 - 5.5		SKC 20 - 6.5	6.0 - 6.5		SKC25 - 19	18.5 - 19.0
	SKC16 - 6	5.5 - 6.0		SKC 20 - 7	6.5 - 7.0		SKC25 - 19.5	19.0 - 19.5
	SKC16 - 6.5	6.0 - 6.5		SKC 20 - 7.5	7.0 - 7.5		SKC25 - 20	19.5 - 20.0
	SKC16 - 7	6.5 - 7.0		SKC 20 - 8	7.5 - 8.0		SKC25 - 20.5	20.0 - 20.5
	SKC16 - 7.5	7.0 - 7.5		SKC 20 - 8.5	8.0 - 8.5		SKC25 - 21	20.5 - 21.0
	SKC16 - 8	7.5 - 8.0		SKC 20 - 9	8.5 - 9.0		SKC25 - 21.5	21.0 - 21.5
	SKC16 - 8.5	8.0 - 8.5		SKC 20 - 9.5	9.0 - 9.5		SKC25 - 22	21.5 - 22.0
	SKC16 - 9	8.5 - 9.0		SKC 20 - 10	9.5 - 10.0		SKC25 - 22.5	22.0 - 22.5
	SKC16 - 9.5	9.0 - 9.5		SKC 20 - 10.5	10.0 - 10.5		SKC25 - 23	22.5 - 23.0
	SKC16 - 10	9.5 - 10.0		SKC 20 - 11	10.5 - 11.0		SKC25 - 23.5	23.0 - 23.5
	SKC16 - 10.5	10.0 - 10.5		SKC 20 - 11.5	11.0 - 11.5		SKC25 - 24	23.5 - 24.0
SKC16 - 11	10.5 - 11.0	SKC 20 - 12		11.5 - 12.0	SKC25 - 24.5	24.0 - 24.5		
SKC16 - 11.5	10.0 - 11.5	SKC 20 - 12.5		12.0 - 12.5	SKC25 - 25	24.5 - 25.0		
SKC16 - 12	11.5 - 12.0	SKC 20 - 13		12.5 - 13.0	SKC25 - 25.4	25.0 - 25.4		
SKC16 - 12.5	12.0 - 12.5	SKC 20 - 13.5		13.0 - 13.5				
SKC16 - 13	12.5 - 13.0	SKC 20 - 14	13.5 - 14.0					
SKC16 - 13.5	13.0 - 13.5	SKC 20 - 14.5	14.0 - 14.5					
SKC16 - 14	13.5 - 14.0	SKC 20 - 15	14.5 - 15.0					
SKC16 - 14.5	14.0 - 14.5	SKC 20 - 15.5	15.0 - 15.5					
SKC16 - 15	14.5 - 15.0	SKC 20 - 16	15.5 - 16.0					
SKC16 - 15.5	15.0 - 15.5	SKC 20 - 16.5	16.0 - 16.5					
SKC16 - 16	15.5 - 16.0	SKC 20 - 17	16.5 - 17.0					
		SKC 20 - 17.5	17.0 - 17.5					
		SKC 20 - 18	17.5 - 18.0					
		SKC 20 - 18.5	18.0 - 18.5					
		SKC 20 - 19	18.5 - 19.0					
		SKC 20 - 19.5	19.0 - 19.5					
		SKC 20 - 20.0	19.5 - 20.0					



SKN NUT
SKN NUSS

TOOL
HOLDERS

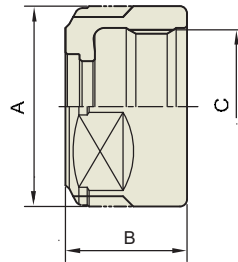

FIG 1

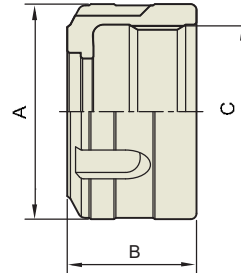
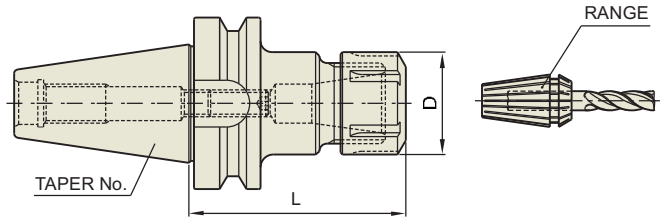

FIG 2

TYPE	FIG	A	B	C	Weight (kg)
SKN 06	1	20	15	M15.5X1.0	0.02
SKN 10	1	28	17	M21.5X1.0	0.04
SKN 13	2	33	21	M27X1.0	0.05
SKN 16	2	40	24	M32X1.5	0.06
SKN 20	2	48.5	24	M40X1.0	0.08
SKN 25	2	55	30	M42X1.5	0.10

ER COLLET CHUCK FRÄSERSPANNFUTTE

MAS403-BT



MAS403-BT	Taper Accuracy AT3	G Value 6.3	RPM 12,000	Coolant System
-----------	-----------------------	----------------	---------------	----------------

■ STANDARD TYPE

TAPER No.	CODE No.	RANGE	D	L	M	NUT	COLLET	Weight (kg)
30	BT30-ER11- 70	0.5~7.0	19	70	M6	ER11	ER11 +ET1-12	0.5
	BT30-ER11-100	0.5~7.0	19	100	M6	ER11	ER11 +ET1-12	0.5
	BT30-ER16- 70	0.5~10.0	28	70	M10	ER16	ER16+ET1-16	1.0
	BT30-ER16-100	0.5~10.0	28	100	M10	ER16	ER16+ET1-16	1.1
	BT30-ER20- 80	1.0~13.0	34	80	M12	ER20	ER20+ET1-20	1.2
	BT30-ER20-100	1.0~13.0	34	100	M12	ER20	ER20+ET1-20	1.3
	BT30-ER25- 70	1.0~16.0	42	70	M12	ER25	ER25+ET1-25	1.2
	BT30-ER25-100	1.0~16.0	42	100	M12	ER25	ER25+ET1-25	1.3
40	BT40-ER11- 75	0.5~7.0	19	75	M6	ER11	ER11 +ET1-12	1.0
	BT40-ER11-100	0.5~7.0	19	100	M6	ER11	ER11 +ET1-12	1.1
	BT40-ER16- 75	0.5~10.0	28	75	M10	ER16	ER16+ET1-16	1.1
	BT40-ER16-100	0.5~10.0	28	100	M10	ER16	ER16+ET1-16	1.2
	BT40-ER16-120	0.5~10.0	28	120	M10	ER16	ER16+ET1-16	1.4
	BT40-ER20- 75	1.0~13.0	34	75	M12	ER20	ER20+ET1-20	1.4
	BT40-ER20-100	1.0~13.0	34	100	M12	ER20	ER20+ET1-20	1.8
	BT40-ER20-135	1.0~13.0	34	135	M12	ER20	ER20+ET1-20	2.2
	BT40-ER25- 75	1.0~16.0	42	75	M12	ER25	ER25+ET1-25	1.4
	BT40-ER25-100	1.0~16.0	42	100	M12	ER25	ER25+ET1-25	1.8
	BT40-ER25-135	1.0~16.0	42	135	M12	ER25	ER25+ET1-25	2.2
	BT40-ER25-150	1.0~16.0	42	150	M12	ER25	ER25+ET1-25	2.4
	BT40-ER32- 60	2.0~20.0	50	60	M12	ER32	ER32+ET1-32	1.8
	BT40-ER32-100	2.0~20.0	50	100	M12	ER32	ER32+ET1-32	2.2
	BT40-ER32-120	2.0~20.0	50	120	M12	ER32	ER32+ET1-32	2.4
	BT40-ER32-150	2.0~20.0	50	150	M12	ER32	ER32+ET1-32	2.6
BT40-ER40- 80	3.0~30.0	63	80	M12	ER40	ER40+ET1-40	1.5	

- ▶ For usable collet, please refer to page 1118 and 1119
- ▶ Higher balancing grade product could be supplied by customer's request.

**ER COLLET CHUCK
FRÄSERSPANNFUTTE**

MAS403-BT

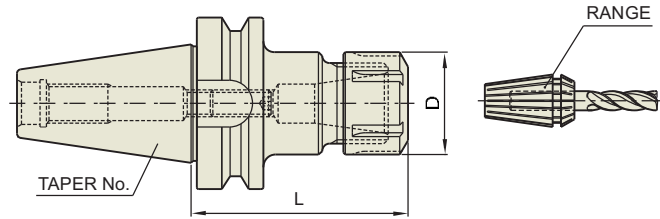

MAS403 -BT	Taper Accuracy AT3	G Value 6.3	RPM 12,000	Coolant System
---------------	--------------------------	----------------	---------------	-------------------

STANDARD TYPE

TAPER No.	CODE No.	RANGE	D	L	M	NUT	COLLET	Weight (kg)
50	BT50-ER16-100	0.5~10.0	28	100	M10	ER16	ER16+ET1-16	4.2
	BT50-ER16-120	0.5~10.0	28	120	M10	ER16	ER16+ET1-16	4.4
	BT50-ER16-165	0.5~10.0	28	165	M10	ER16	ER16+ET1-16	4.6
	BT50-ER20-100	1.0~13.0	34	100	M12	ER20	ER20+ET1-20	4.6
	BT50-ER20-135	1.0~13.0	34	135	M12	ER20	ER20+ET1-20	4.8
	BT50-ER20-165	1.0~13.0	34	165	M12	ER20	ER20+ET1-20	5.0
	BT50-ER25-100	1.0~16.0	42	100	M12	ER25	ER25+ET1-25	4.7
	BT50-ER25-135	1.0~16.0	42	135	M12	ER25	ER25+ET1-25	4.8
	BT50-ER25-165	1.0~16.0	42	165	M12	ER25	ER25+ET1-25	5.0
	BT50-ER32-100	2.0~20.0	50	100	M12	ER32	ER32+ET1-32	5.2
	BT50-ER32-135	2.0~20.0	50	135	M12	ER32	ER32+ET1-32	5.7
	BT50-ER32-165	2.0~20.0	50	165	M12	ER32	ER32+ET1-32	5.8
	BT50-ER40-100	3.0~30.0	63	100	M12	ER40	ER40+ET1-40	5.6
	BT50-ER40-150	3.0~30.0	63	150	M12	ER40	ER40+ET1-40	6.1
BT50-ER50-100	12.0~34.0	78	100	M12	ER50	ER40+ET1-40	5.8	
BT50-ER50-150	12.0~34.0	78	150	M12	ER50	ER40+ET1-40	6.3	

- ▶ For usable collet, please refer to page 1118 and 1119
- ▶ Higher balancing grade product could be supplied by customer's request.

ER COLLET CHUCK FRÄSERSPANNFUTTE

DIN69893-HSK FORM A

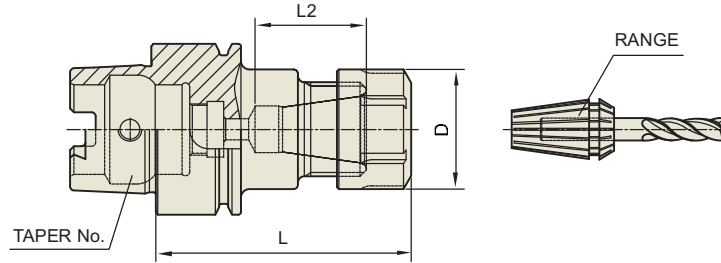

DIN69893 - HSK	Taper Accuracy AT3	G Value 6.3	RPM 12,000	Coolant System
-------------------	--------------------------	----------------	---------------	-------------------

STANDARD TYPE

TAPER No.	CODE No.	RANGE	D	L	L2	NUT	Weight (kg)
40A	HSK40A-ER11-60	0.5 ~ 7.0	19	60	22	ER 11	0.40
	HSK40A-ER16-60	0.5 ~ 10.0	28	60	26	ER 16	0.50
	HSK40A-ER20-70	1.0 ~ 13.0	34	70	33	ER 20	0.80

SLIM TYPE

TAPER No.	CODE No.	RANGE	D	L	L2	NUT	Weight (kg)
40A	HSK40A-ER11M-75	0.5 ~ 7.0	16	75	22	ER11M	0.40
	HSK40A-ER16M-80	0.5 ~ 10.0	22	80	26	ER16M	0.50
	HSK40A-ER20M-80	1.0 ~ 13.0	28	80	33	ER20M	0.70
	HSK40A-ER25M-80	1.0 ~ 16.0	35	80	40	ER25M	0.80

► Higher balancing grade product could be supplied by customer's request.

DIN69893-HSK FORM E

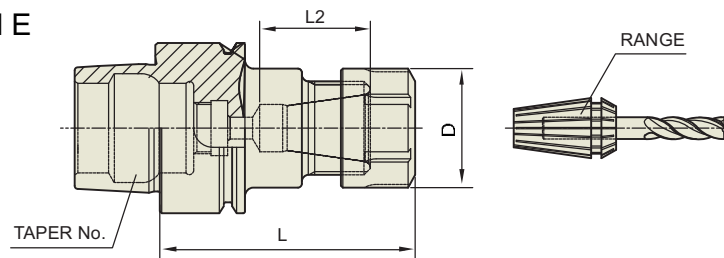

STANDARD TYPE

TAPER No.	CODE No.	RANGE	D	L	L2	NUT	Weight (kg)
40E	HSK40E-ER11-60	0.5 ~ 7.0	19	60	22	ER 11	0.40
	HSK40E-ER16-60	0.5 ~ 10.0	28	60	26	ER 16	0.50
	HSK40E-ER20-70	1.0 ~ 13.0	34	70	33	ER 20	0.80

SLIM TYPE

TAPER No.	CODE No.	RANGE	D	L	L2	NUT	Weight (kg)
40E	HSK40E-ER11M-75	0.5 ~ 7.0	16	75	22	ER11M	0.40
	HSK40E-ER16M-80	0.5 ~ 10.0	22	80	26	ER16M	0.50
	HSK40E-ER20M-80	1.0 ~ 13.0	28	80	33	ER20M	0.70
	HSK40E-ER25M-80	1.0 ~ 16.0	35	80	40	ER25M	0.80

► Higher balancing grade product could be supplied by customer's request.



**ER COLLET CHUCK
FRÄSERSPANNFUTTE**

TOOL
HOLDERS

DIN69893-HSK FORM A

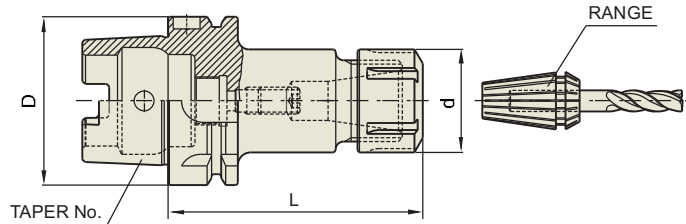

DIN69893 - HSK	Taper Accuracy AT3	G Value 6.3	RPM 12,000	Coolant System
-------------------	--------------------------	----------------	---------------	-------------------

TAPER No.	CODE No.	RANGE	d	D	L	Weight (kg)
50A	HSK 50A-ER16-100	0.5-10	28	50	100	0.70
	HSK 50A-ER20-100	1-13	35	50	100	0.90
	HSK 50A-ER25-100	1-16	42	50	100	1.20
	HSK 50A-ER32-100	2-20	50	50	100	1.50
63A	HSK 63A-ER16-100	0.5-10	28	63	100	1.20
	HSK 63A-ER20-100	1-13	35	63	100	1.50
	HSK 63A-ER25-100	1-16	42	63	100	1.80
	HSK 63A-ER32-100	2-20	50	63	100	2.00
	HSK 63A-ER40-120	3-26	63	63	120	2.30
100A	HSK100A-ER16-100	0.5-10	28	100	100	2.60
	HSK100A-ER20-100	1-13	35	100	100	2.70
	HSK100A-ER25-100	1-16	42	100	100	2.90
	HSK100A-ER32-100	2-20	50	100	100	3.10
	HSK100A-ER40-120	3-26	63	100	120	3.30

- ▶ Higher balancing grade product could be supplied by customer's request.
- ▶ Internal oil supply mode is applicable when using ERC nut.

ERC NUT

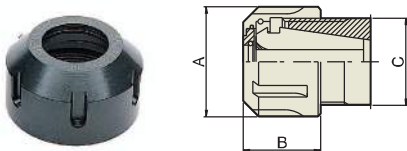

TYPE
HI-Q/ERC16
HI-Q/ERC20
HI-Q/ERC25
HI-Q/ERC32
HI-Q/ERC40

SEALING DISK

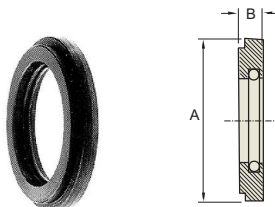

TYPE
DS/ER16
DS/ER20
DS/ER25
DS/ER32
DS/ER40

ER COLLET CHUCK FRÄSERSPANNFUTTE

DIN69871-SK

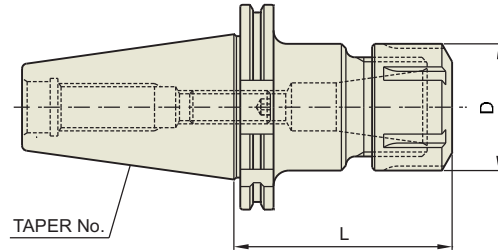

DIN69871 -SK	Taper Accuracy AT3	G Value 6.3	RPM 12,000	Coolant System
-----------------	--------------------------	----------------	---------------	-------------------

STANDARD

TAPER No.	CODE No.	RANGE	D	L	NUT	Weight (kg)
30	SK30-ER11-55	0.5~7.0	19	55	ER11	
	SK30-ER16-55	0.5~10.0	28	55	ER16	
	SK30-ER20-55	1.0~13.0	34	55	ER20	
	SK30-ER25-55	1.0~16.0	42	55	ER25	
	SK30-ER32-60	2.0~20.0	50	60	ER32	
40	SK40-ER11-70	0.5~7.0	19	70	ER11	
	SK40-ER16-70	0.5~10.0	28	70	ER16	
	SK40-ER20-70	1.0~13.0	34	70	ER20	
	SK40-ER25-70	1.0~16.0	42	70	ER25	
	SK40-ER32-70	2.0~20.0	50	70	ER32	
50	SK40-ER40-80	3.0~30.0	63	80	ER40	
	SK50-ER16-70	0.5~10.0	28	70	ER16	
	SK50-ER20-70	1.0~13.0	34	70	ER20	
	SK50-ER25-70	1.0~16.0	42	70	ER25	
	SK50-ER32-70	2.0~20.0	50	70	ER32	
	SK50-ER40-80	3.0~30.0	63	80	ER40	

EXTENDED

TAPER No.	CODE No.	RANGE	D	L	NUT	Weight (kg)
40	SK40-ER16-100	0.5~10.0	28	100	ER16	
	SK40-ER20-100	1.0~13.0	34	100	ER20	
	SK40-ER25-100	1.0~16.0	42	100	ER25	
	SK40-ER32-100	2.0~20.0	50	100	ER32	
50	SK50-ER16-100	0.5~10.0	28	100	ER16	
	SK50-ER20-100	1.0~13.0	34	100	ER20	
	SK50-ER25-100	1.0~16.0	42	100	ER25	
	SK50-ER32-100	2.0~20.0	50	100	ER32	
	SK50-ER40-100	3.0~30.0	63	100	ER40	

- ▶ For usable collet, please refer to page 1118 and 1119
- ▶ Higher balancing grade product could be supplied by customer's request.

ER COLLET CHUCK FRÄSERSPANNFUTTE

DIN69871-SK(AD/B)

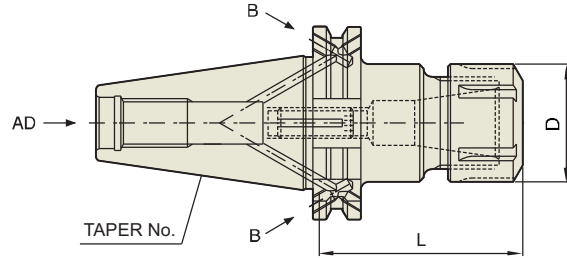

DIN69871 -SK	Taper Accuracy AT3	G Value 6.3	RPM 12,000	Coolant System
-----------------	--------------------------	----------------	---------------	-------------------

STANDARD

TAPER No.	CODE No.	RANGE	D	L	NUT	Weight (kg)
40	SK40AD/B-ER11-70	0.5~7.0	19	70	ER11	0.80
	SK40AD/B-ER16-70	0.5~10.0	28	70	ER16	0.90
	SK40AD/B-ER20-70	1.0~13.0	34	70	ER20	1.20
	SK40AD/B-ER25-70	1.0~16.0	42	70	ER25	1.30
	SK40AD/B-ER32-70	2.0~20.0	50	70	ER32	1.50
50	SK40AD/B-ER40-80	3.0~30.0	63	80	ER40	1.70
	SK50AD/B-ER16-70	0.5~10.0	28	70	ER16	2.80
	SK50AD/B-ER20-70	1.0~13.0	34	70	ER20	2.90
	SK50AD/B-ER25-70	1.0~16.0	42	70	ER25	3.10
	SK50AD/B-ER32-70	2.0~20.0	50	70	ER32	3.30
	SK50AD/B-ER40-80	3.0~30.0	63	80	ER40	3.50

EXTENDED

TAPER No.	CODE No.	RANGE	D	L	NUT	Weight (kg)
40	SK40AD/B-ER16-100	0.5~10.0	28	100	ER16	1.05
	SK40AD/B-ER20-100	1.0~13.0	34	100	ER20	1.13
	SK40AD/B-ER25-100	1.0~16.0	42	100	ER25	1.35
	SK40AD/B-ER32-100	2.0~20.0	50	100	ER32	1.43
50	SK50AD/B-ER16-100	0.5~10.0	28	100	ER16	2.90
	SK50AD/B-ER20-100	1.0~13.0	34	100	ER20	3.10
	SK50AD/B-ER25-100	1.0~16.0	42	100	ER25	3.30
	SK50AD/B-ER32-100	2.0~20.0	50	100	ER32	3.50
	SK50AD/B-ER40-100	3.0~26.0	63	100	ER40	3.80

- ▶ For usable collet, please refer to page 1118 and 1119
- ▶ Higher balancing grade product could be supplied by customer's request.

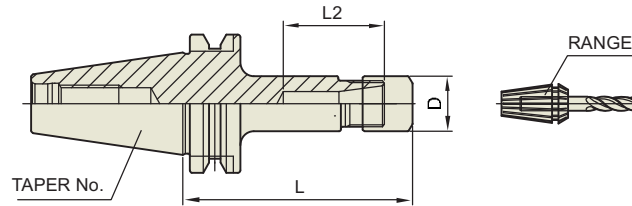
**ER COLLET CHUCK
FRÄSERSPANNFUTTE**
MAS403-BT

MAS403 -BT	Taper Accuracy AT3	G Value	RPM	Coolant System
---------------	--------------------------	---------	-----	-------------------

TAPER No.	CODE No.	RANGE	D	L	L2	Weight (kg)
BT20	BT20-ER8M-50	0.5 ~ 5.0	12	50	22	
	BT20-ER11M-50	0.5 ~ 7.0	16	50	22	
	BT20-ER16M-50	0.5 ~ 10.0	22	50	26	
	BT20-ER11-50	0.5 ~ 7.0	19	50	22	
	BT20-ER16-50	0.5 ~ 10.0	28	50	26	
BT25	BT25-ER8M-50	0.5 ~ 5.0	12	50	22	
	BT25-ER11M-50	0.5 ~ 7.0	16	50	22	
	BT25-ER16M-50	0.5 ~ 10.0	22	50	26	
	BT25-ER11-50	0.5 ~ 7.0	19	50	22	
	BT25-ER16-50	0.5 ~ 10.0	28	50	26	



**ER COLLET CHUCK
FRÄSERSPANNFUTTE**

MTA

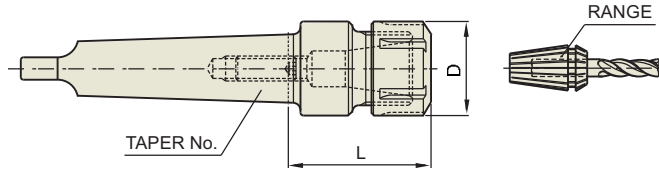

DIN228 - MTA	Taper Accuracy AT3	G Value	RPM	Coolant System
-----------------	--------------------------	---------	-----	-------------------

■ STANDARD TYPE

TAPER No.	CODE No.	RANGE	D	L	NUT	COLLET	Weight (kg)
1	MTA1-ER11	0.5-7.0	19	35	ER11	ER11	0.30
	MTA1-ER16	0.5-10	28	40	ER16	ER16	0.35
2	MTA2-ER20	1-13	34	50	ER20	ER20	0.50
	MTA2-ER25	1-16	42	50	ER25	ER25	0.60
3	MTA3-ER25	1-16	42	60	ER25	ER25	0.60
	MTA3-ER32	2-20	50	70	ER32	ER32	0.65
4	MTA4-ER20	1-13	34	60	ER20	ER20	1.00
	MTA4-ER25	1-16	42	60	ER25	ER25	1.10
	MTA4-ER32	2-20	50	65	ER32	ER32	1.30
	MTA4-ER40	3-30	63	80	ER40	ER40	1.50
5	MTA5-ER32	2-20	50	70	ER32	ER32	2.20
	MTA5-ER40	3-30	63	80	ER40	ER40	2.40
	MTA5-ER50	6-34	78	80	ER50	ER50	2.80

ER COLLET CHUCK FRÄSERSPANNFUTTE

MTB

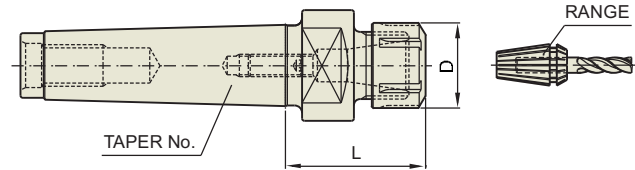

DIN228 - MTB	Taper Accuracy AT3	G Value	RPM	Coolant System
-----------------	--------------------------	---------	-----	-------------------

STANDARD TYPE

TAPER No.	CODE No.	RANGE	D	L	NUT	COLLET	Weight (kg)
1	MTB1-ER16	1-10	28	40	ER16	ER16	0.35
2	MTB2-ER20	1-13	34	50	ER20	ER20	0.50
	MTB2-ER25	1-16	42	50	ER25	ER25	0.60
3	MTB3-ER25	1-16	42	60	ER25	ER25	0.60
	MTB3-ER32	2-20	50	70	ER32	ER32	0.65
4	MTB4-ER32	2-20	50	70	ER32	ER32	1.10
	MTB4-ER40	3-30	63	80	ER40	ER40	1.30
5	MTB5-ER32	2-20	50	70	ER32	ER32	2.00
	MTB5-ER40	3-30	63	80	ER40	ER40	2.20
	MTB5-ER50	6-34	78	80	ER50	ER50	2.60



**ER CHUCK
FRASERSPANNFUTTER**

TOOL
HOLDERS

K

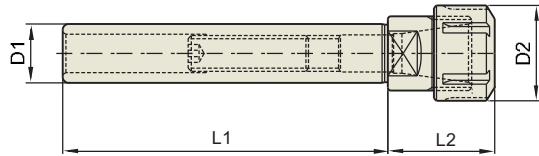

K

Taper Accuracy
AT3

G Value

RPM

Coolant System

■ STANDARD TYPE

TAPER No.	CODE No.	RANGE	D1	D2	L1	L2	NUT	COLLET	Weight (kg)
16	K16-ER11-100	0.5-7.0	16	19	100	32	ER11	ER11	0.15
	K16-ER16-100	0.5-10.0	16	28	100	36	ER16	ER16	0.18
20	K20-ER16-100	0.5-10.0	20	28	100	36	ER16	ER16	0.25
	K20-ER20-100	1.0-13.0	20	34	100	40	ER20	ER20	0.29
	K20-ER25-100	1.0-16.0	20	42	100	50	ER25	ER25	0.35
25	K25-ER20-100	1.0-13.0	25	34	100	40	ER20	ER20	0.40
	K25-ER25-100	1.0-16.0	25	42	100	50	ER25	ER25	0.45
32	K32-ER16-100	0.5-10.0	32	28	100	36	ER16	ER16	0.50
	K32-ER20-100	1.0-13.0	32	34	100	40	ER20	ER20	0.66
	K32-ER25-100	1.0-16.0	32	42	100	50	ER25	ER25	0.75
	K32-ER32-100	2.0-20.0	32	50	100	58	ER32	ER32	1.00

TOOL
HOLDERS

EXTENSION ER COLLET CHUCK - SLIM TYPE VERLÄNGERUNG FRÄSERSPANNFUTTER - SCHLANKER TYP

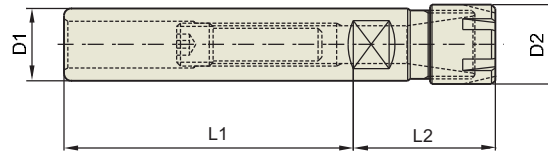

K	Taper Accuracy AT3	G Value	RPM	Coolant System
---	-----------------------	---------	-----	----------------

TAPER No.	CODE No.	RANGE	D1	D2	L1	L2	NUT	Weight (kg)
12	K12-ER8M-70	0.5-5.0	12	12	70	25	ERM 8	0.10
16	K16-ER11M-140	0.5-7.0	16	16	140	32	ERM11	0.22
20	K20-ER16M-140	0.5-10.0	20	22	140	41	ERM16	0.32
	K20-ER20M-140	1.0-13.0	20	28	140	41	ERM20	0.35
25	K25-ER16M-140	0.5-10.0	25	22	140	41	ERM16	0.45
	K25-ER20M-140	1.0-13.0	25	28	140	41	ERM20	0.52
	K25-ER25M-140	1.0-16.0	25	35	140	45	ERM25	0.55

TENSION ER CHUCK - Exclusive use for tapping SPANNUNG FRÄSERSPANNFUTTER - für GEWINDESCHNEID

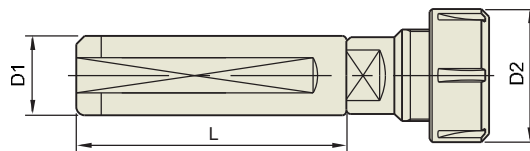

K	Taper Accuracy AT3	G Value	RPM	Coolant System
---	-----------------------	---------	-----	----------------

TAPER No.	CODE No.	RANGE	D1	D2	L	NUT	Weight (kg)
20	K20-ERT16-70	0.5-10.0	20	28	70	ER16	0.4
25	K25-ERT16-70	0.5-10.0	25	28	70	ER16	0.45
	K25-ERT20-80	1.0-13.0	25	34	80	ER20	0.50
32	K32-ERT16-70	0.5-10.0	32	28	70	ER16	0.70
	K32-ERT20-80	1.0-13.0	32	34	80	ER20	0.80
	K32-ERT25-80	1.0-16.0	32	42	80	ER25	1.00
	K32-ERT32-80	2.0-20.0	32	50	80	ER32	1.20



ER COLLET CHUCK for CNC LATHE - NC
FRÄSERSPANNFUTTER FÜR CNC DREHBANK

TOOL
HOLDERS

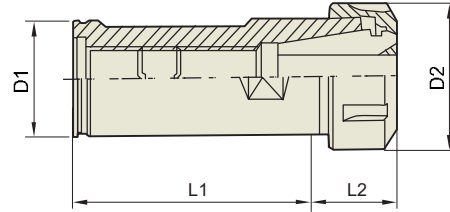

NC	Taper Accuracy AT3	G Value	RPM	Coolant System
----	-----------------------	---------	-----	----------------

■ **STANDARD TYPE**

TAPER No.	CODE No.	RANGE	D1	D2	L1	L2	NUT	COLLET	Weight (kg)
25	NC25-ER11	0.5-7.0	25	19	65	32	ER11	ER11	0.30
	NC25-ER16	0.5-10.0	25	28	65	32	ER16	ER16	0.45
	NC25-ER20	1.0-13.0	25	34	65	32	ER20	ER20	0.50
	NC25-ER25	1.0-16.0	25	42	65	32	ER25	ER25	0.55
32	NC32-ER20	1.0-13.0	32	34	70	32	ER20	ER20	0.60
	NC32-ER25	1.0-16.0	32	42	70	38	ER25	ER25	0.70
	NC32-ER32	2.0-20.0	32	50	60	38	ER32	ER32	0.75
40	NC40-ER32	2.0-20.0	40	50	75	53	ER32	ER32	1.25
	NC40-ER40	3.0-30.0	40	63	75	53	ER40	ER40	1.30

ER COLLET CHUCK for BRIDGEPORT - R8
FRÄSERSPANNFUTTER für R8

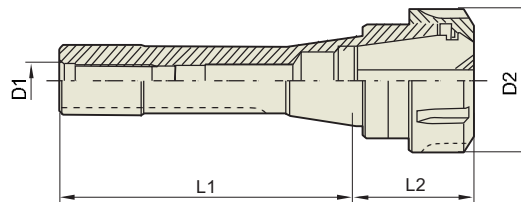

TAPER No.	CODE No.	RANGE	D1	D2	L1	L2	NUT	COLLET	Weight (kg)
R8	R8-ER32	2-20.0	U7/16	50	101.5	50	ER32	ER32	1.00
	R8-ER40	3-30.0	U7/16	63	101.5	75	ER40	ER40	1.20

ER COLLET - UF
ER SPANNZANGE -UF



TYPE ER 8		TYPE ER11		TYPE ER16		TYPE ER20	
CLAMPING CAPACITY	ITEM No.	CLAMPING CAPACITY	ITEM No.	CLAMPING CAPACITY	ITEM No.	CLAMPING CAPACITY	ITEM No.
1.0-0.5	208010	1.0-0.5	211010	1.0-0.5	216010	2-1	220020
1.5-1.0	208015	1.5-1.0	211015	2.0-1.0	216020	3-2	220030
2.0-1.5	208020	2.0-1.5	211020	3.0-2.0	216030	4-3	220040
2.5-2.0	208025	2.5-2.0	211025	4.0-3.0	216040	5-4	220050
3.0-2.5	208030	3.0-2.5	211030	5.0-4.0	216050	6-5	220060
3.5-3.0	208035	3.5-3.0	211035	6.0-5.0	216060	7-6	220070
4.0-3.5	208040	4.0-3.5	211040	7.0-6.0	216070	8-7	220080
4.5-4.0	208045	4.5-4.0	211045	8.0-7.0	216080	9-8	220090
5.0-4.5	208050	5.0-4.5	211050	9.0-8.0	216090	10-9	220100
		5.5-5.0	211055	10.0-9.0	216100	11-10	220120
		6.0-5.5	211060	1.5-1.0	216015	12-11	220130
		6.5-6.0	211065	2.5-2.0	216025	13-12	220140
		7.0-6.5	211070			1.0-0.5	220010
						1.5-1.0	220015
						2.5-2.0	220025
STANDARD SET	208000	STANDARD SET	211000	STANDARD SET	216000	STANDARD SET	220000
Ø 1.0-5.0mm 9PCS		Ø 1.0-7.0mm 13PCS		Ø 1.0-10.0mm 10PCS		Ø 2.0-13.0mm 12PCS	
WOODEN TRAY ZWT 8	108110	WOODEN TRAY ZWT 11	011110	WOODEN TRAY ZWT 16	016110	WOODEN TRAY ZWT 20	020110



ER COLLET - UF
ER SPANNZANGE -UF

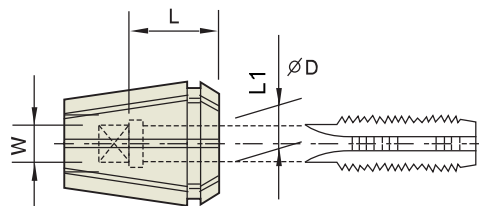

TYPE ER25		TYPE ER32		TYPE ER40		TYPE ER50	
CLAMPING CAPACITY	ITEM No.	CLAMPING CAPACITY	ITEM No.	CLAMPING CAPACITY	ITEM No.	CLAMPING CAPACITY	ITEM No.
2-1	225020	3-2	232030	4-3	240040	12-10	250120
3-2	225030	4-3	232040	5-4	240050	14-12	250140
4-3	225040	5-4	232050	6-5	240060	16-14	250160
5-4	225050	6-5	232060	7-6	240070	18-16	250180
6-5	225060	7-6	232070	8-7	240080	20-18	250200
7-6	225070	8-7	232080	9-8	240090	22-20	250220
8-7	225080	9-8	232090	10-9	240100	24-22	250240
9-8	225090	10-9	232100	11-10	240110	26-24	250260
10-9	225100	11-10	232110	12-11	240120	28-26	250280
11-10	225110	12-11	232120	13-12	240130	30-28	250300
12-11	225120	13-12	232130	14-13	240140	32-30	250320
13-12	225130	14-13	232140	15-14	240150	34-32	250340
14-13	225140	15-14	232150	16-15	240160	6-4	250060
15-14	225150	16-15	232160	17-16	240170	8-6	250080
16-15	225160	17-16	232170	18-17	240180	10-8	250100
1.0-1.5	225010	18-17	232180	19-18	240190	25-23	250250
1.5-1.0	225015	19-18	232190	20-19	240200		
2.5-2.0	225025	20-19	232200	21-20	240210		
		2.0-1.0	232020	22-21	240220		
		2.5-2.0	232025	23-22	240230		
				24-23	240240		
				25-24	240250		
				26-25	240260		
				3-2	240030		
				27-26	240270		
				28-27	240280		
				29-28	240290		
				30-29	240300		
STANDARD SET	225000	STANDARD SET	232000	STANDARD SET	240000	STANDARD SET	250000
Ø 2.0-16.0mm 15PCS		Ø 3.0-20.0mm 18PCS		Ø 4.0-26.0mm 23PCS		Ø 12.0-34.0mm 12PCS	
WOODEN TRAY ZWT 25	025110	WOODEN TRAY ZWT 32	032110	WOODEN TRAY ZWT 40	040110	WOODEN TRAY ZWT50	050110

ER COLLET FOR EXCLUSIVE USE FOR TAP
ER SPANNZANGE FÜR GEWINDESCHNEID

RDT 16				RDT 20				RDT 25				RDT 32				RDT 40			
TAP	Ø	W	L	TAP	Ø	W	L	TAP	Ø	W	L	TAP	Ø	W	L	TAP	Ø	W	L
M2	3.0	2.5	15																
M3	4.0	3.2	15	M3	4.0	3.2	15	M3	4.0	3.2	15								
M4	5.0	4.0	15	M4	5.0	4.0	15	M4	5.0	4.0	15	M4	5.0	4.0	15				
M5	5.5	4.5	15	M5	5.5	4.5	15	M5	5.5	4.5	15	M5	5.5	4.5	15				
M6	6.0	4.5	15	M6	6.0	4.5	15	M6	6.0	4.5	15	M6	6.0	4.5	15				
M8	6.2	5.0	15	M8	6.2	5.0	20	M8	6.2	5.0	20	M8	6.2	5.0	20	M8	6.2	5.0	20
				M10	7.0	5.5	20	M10	7.0	5.5	20	M10	7.0	5.5	20	M10	7.0	5.5	20
								M12	8.5	6.5	20	M12	8.5	6.5	20	M12	8.5	6.5	25
								M14	10.5	8.0	20	M14	10.5	8.0	20	M14	10.5	8.0	25
												M16	12.5	10.0	20	M16	12.5	10.0	25
												M18	14.0	11.0	20	M18	14.0	11.0	25
																M20	15.0	12.0	28
																M22	17.0	13.0	28
																M24	19.0	15.0	28

- ▶ These ER collets are for exclusive use for tap.
- ▶ Various sizes of taps ranging from M2 to M24 can be used.

**ER SPANNER / WRENCH
ER MAULSCHLÜSSEL**

FIG. 1



FIG. 2

SPANNER FOR ER/SKN NUT

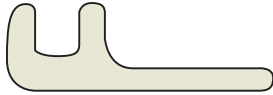
TYPE	ITEM No.	A	B	APPLICABLE NUT
ER16 SP	916 181	50	160	ER16, SKN10 (FIG 1.)
ER20 SP	920 181	55	180	ER20 (FIG 1.)
ER25 SP	925 180	65	210	ER25, SKN16 (FIG 2.)
ER32 SP	932 180	75	250	ER32 (FIG 2.)
ER40 SP	940 180	90	290	ER40 (FIG 2.)
ER50 SP	950 180	110	350	ER50 (FIG 2.)

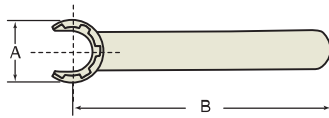
SPANNER FOR EM NUT

TYPE	ITEM No.	A	B	APPLICABLE NUT
E 8M	908 160	12.4	70	HI-Q/ERM 8
E 11M	911 160	16.8	90	HI-Q/ERM 11
E 16M	916 160	22.5	110	HI-Q/ERM 16
E 20M	920 160	29.0	120	HI-Q/ERM 20
E 25M	925 160	36.0	130	HI-Q/ERM 25

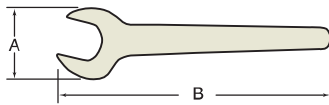
SPANNER FOR GS NUT

TYPE	ITEM No.	A	B	APPLICABLE NUT
GS17	911 180	32.0	95	HI-Q/ER11
GS25	916 180	44.0	144	HI-Q/ER16
GS30	920 180	52.5	172	HI-Q/ER20

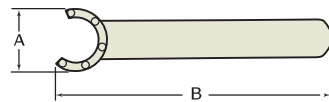
EM NUT (FOR FLOATING CHUCK)

Type EAX

TYPE	ITEM No.	A	B	APPLICABLE NUT
E 11AX	711 170	16.5	108	ER 11-AXC
E 16AX	716 170	22.5	131	ER 16-AXC
E 20AX	720 170	26	148	ER 20-AXC
E 25AX	725 170	29.5	162	ER 25-AXC
E 32AX	732 170	37.5	196	ER 32-AXC

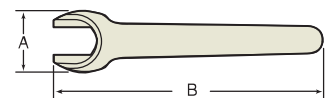
SPANNER FOR EM NUT

TYPE	ITEM No.	A	B	APPLICABLE NUT
E 8MS	908 161	19.2	76	ER 8-MS
E 11MS	911 161	22.0	100	ER 11-MS
E 16MS	916 161	33.0	130	ER 16-MS
E 20MS	920 161	42.0	140	ER 20-MS

TOOL
HOLDERS

NC DRILL CHUCK NC - BOHRFUTTER

MAS403-BT

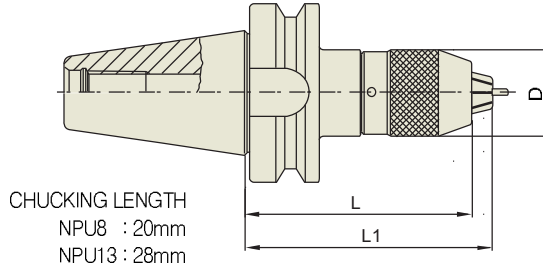

MAS403 -BT	Taper Accuracy AT3	G Value	RPM	Coolant System
---------------	--------------------------	---------	-----	-------------------

TAPER No.	CODE No.	CAPACITY	D	L(MIN)	L1(MAX)	Weight (kg)
30	BT30-NPU 8- 70	0.3~8	36.5	70	75.7	0.80
	BT30-NPU13-100	1~13	50.4	100	110	1.80
40	BT40-NPU 8- 70	0.3~8	36.5	70	75.7	1.50
	BT40-NPU 8-110	0.3~8	36.5	110	115.7	1.80
	BT40-NPU 8-150	0.3~8	36.5	150	155.7	2.60
	BT40-NPU13- 90	1~13	50.4	90	95.7	2.10
	BT40-NPU13-130	1~13	50.4	130	140	2.70
	BT40-NPU13-150	1~13	50.4	150	160	3.40
50	BT50-NPU 8- 90	0.3~8	36.5	90	95.7	4.20
	BT50-NPU 8-110	0.3~8	36.5	110	115.7	4.50
	BT50-NPU 8-170	0.3~8	36.5	170	180.7	5.20
	BT50-NPU13-100	1~13	50.4	100	110	4.80
	BT50-NPU13-130	1~13	50.4	130	140	5.20
	BT50-NPU13-150	1~13	50.4	150	160	5.50
	BT50-NPU13-190	1~13	50.4	190	200	5.90



NC DRILL CHUCK - K NC - BOHRFUTTER - K

TOOL
HOLDERS

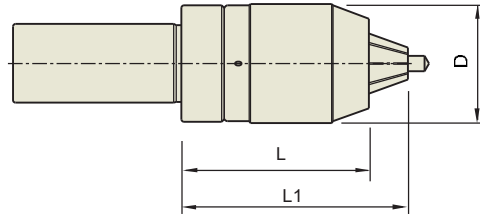

K	Taper Accuracy AT3	G Value	RPM	Coolant System
---	-----------------------	---------	-----	----------------

TAPER No.	CODE No.	CAPACITY	D	L(MIN)	L1(MAX)	d	Weight (kg)
32	K32-NPU 8- 70	0.3~8	36.5	70	75.7	32	0.70
	K32-NPU13-100	1~13	50.4	100	110	32	1.50
42	K42-NPU 8- 70	0.3~8	36.5	70	75.7	42	0.80
	K42-NPU13-100	1~13	50.4	100	110	42	1.60

JACOBS TAPER ADAPTER JACOBS KEGELZAPFEN ADAPTER

MAS403-BT

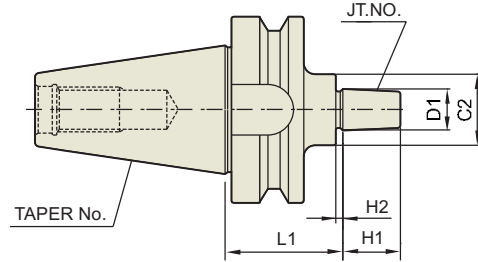

MAS403 -BT	Taper Accuracy AT3	G Value	RPM	Coolant System
---------------	--------------------------	---------	-----	-------------------

TAPER No.	CODE No.	JT. No.	D1	L1	H1	H2	C1	Weight (kg)
30	BT30-JTA 1-45	1	9.754	45	14	3	30	0.9
	BT30-JTA 2-45	2	14.199	45	20	4	30	1.0
	BT30-JTA 6-45	6	17.17	45	24	4	30	1.0
40	BT40-JTA 1-45	1	9.754	45	14	3	30	1.1
	BT40-JTA 1-90	1	9.754	90	14	3	30	1.1
	BT40-JTA2S-45	2Shot	13.94	45	18	3	30	1.4
	BT40-JTA2S-90	2Shot	13.94	90	18	3	30	1.4
	BT40-JTA 2-45	2	14.199	45	20	4	30	1.1
	BT40-JTA 2-90	2	14.199	90	20	4	30	1.4
	BT40-JTA33-45	33	15.85	45	24	4	30	1.1
	BT40-JTA33-90	33	15.85	90	24	4	30	1.4
	BT40-JTA 6-45	6	17.17	45	24	4	30	1.1
	BT40-JTA 6-90	6	17.17	90	24	4	30	1.4
	BT40-JTA 3-45	3	20.599	45	28	5	35	1.2
	BT40-JTA 3-90	3	20.599	90	28	5	35	1.5
50	BT50-JTA 1-45	1	9.754	45	14	3	30	4.0
	BT50-JTA 1-105	1	9.754	105	14	3	30	4.4
	BT50-JTA2S-45	2Shot	13.94	45	18	3	30	4.0
	BT50-JTA2S-105	2Shot	13.94	105	18	3	30	4.4
	BT50-JTA 2-45	2	14.199	45	20	4	30	4.0
	BT50-JTA 2-105	2	14.199	105	20	4	30	4.4
	BT50-JTA33-45	33	15.85	45	24	4	30	4.0
	BT50-JTA33-105	33	15.85	105	24	4	30	4.4
	BT50-JTA 6-45	6	17.17	45	24	4	30	4.0
	BT50-JTA 6-105	6	17.17	105	24	4	30	4.4
	BT50-JTA 3-45	3	20.599	45	28	5	35	4.0
	BT50-JTA 3-105	3	20.599	105	28	5	35	4.6



MORSE TAPER ADAPTER EINSATZHÜLSEN FÜR MORSEKEGEL

TOOL
HOLDERS

MAS403-BT

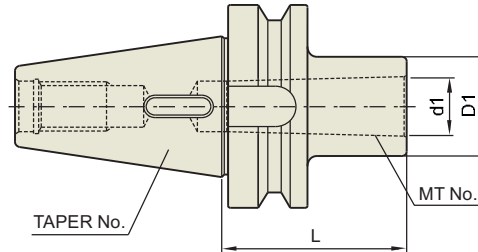

MAS403 -BT	Taper Accuracy AT3	G Value	RPM	Coolant System
---------------	--------------------------	---------	-----	-------------------

TAPER No.	CODE No.	MT No.	L	d1	D1	Weight (kg)
30	BT30-MTA1- 45	1	45	12.065	25	0.4
	BT30-MTA2- 60	2	60	17.780	32	0.5
	BT30-MTA2- 120	2	120	17.780	32	0.6
	BT30-MTA3- 75	3	75	23.825	40	0.7
40	BT40-MTA1- 45	1	45	12.065	25	1.0
	BT40-MTA1-120	1	120	12.065	25	1.3
	BT40-MTA2- 60	2	60	17.780	32	1.0
	BT40-MTA2-120	2	120	17.780	32	1.4
	BT40-MTA3- 75	3	75	23.825	40	1.2
	BT40-MTA3-135	3	135	23.825	40	1.8
	BT40-MTA4- 95	4	95	31.267	50	1.1
	BT40-MTA4-165	4	165	31.267	50	2.4
50	BT50-MTA1- 45	1	45	12.065	25	4.0
	BT50-MTA1-120	1	120	12.065	25	4.3
	BT50-MTA1-180	1	180	12.065	25	4.3
	BT50-MTA2- 45	2	45	17.780	32	4.0
	BT50-MTA2-135	2	135	17.780	32	4.4
	BT50-MTA2-180	2	180	17.780	32	4.6
	BT50-MTA3- 45	3	45	23.825	40	3.9
	BT50-MTA3-150	3	150	23.825	40	4.7
	BT50-MTA3-180	3	180	23.825	40	4.9
	BT50-MTA4- 75	4	75	31.267	50	4.0
	BT50-MTA4-105	4	105	31.267	50	4.5
	BT50-MTA4-180	4	180	31.267	50	5.4
	BT50-MTA5-105	5	105	44.399	65	4.5
	BT50-MTA5-210	5	210	44.399	65	7.2
	BT50-MTA5-270	5	270	44.399	65	7.5

MORSE TAPER ADAPTER EINSATZHÜLSEN FÜR MORSEKEGEL

MAS403-BT

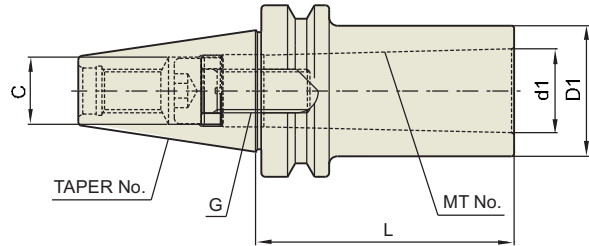

MAS403 -BT	Taper Accuracy AT3	G Value	RPM	Coolant System
---------------	--------------------------	---------	-----	-------------------

TAPER No.	CODE No.	MT No.	L	d1	D1	C	G	Weight (kg)
30	BT30-MTB1-45	1	45	12.065	25	10	M6×1.0	0.8
	BT30-MTB2-45	2	45	17.780	32	—	M10×1.5	0.8
40	BT40-MTB1-45	1	45	12.065	25	10	M6×1.0	1.0
	BT40-MTB2-45	2	45	17.780	32	13.5	M10×1.5	1.1
	BT40-MTB3-60	3	60	23.825	40	—	M12×1.75	1.1
	BT40-MTB4-85	4	85	31.267	50	—	M16×2.0	1.3
50	BT50-MTB1-45	1	45	12.065	25	10	M6×1.0	3.9
	BT50-MTB2-45	2	45	17.780	32	16	M10×1.5	3.9
	BT50-MTB3-60	3	60	23.825	40	18	M12×1.75	3.9
	BT50-MTB4-75	4	75	31.267	50	20.5	M16×2.0	3.9



MORSE TAPER ADAPTER EINSATZHÜLSEN FÜR MORSEKEGEL

TOOL
HOLDERS

NT

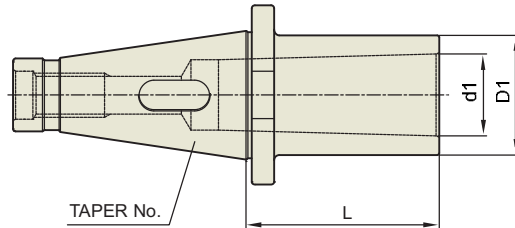

Taper Accuracy	G Value	RPM	Coolant System
AT3			

TAPER No.	CODE No.	MT No.	Range of drill		D1	L	DRAW THREAD	Weight (kg)
			MIN	MAX				
40	NT40-MTA1-30	1	2.0	14.0	25	30	U 5/8-11(M16×2)	0.90
	NT40-MTA2-30	2	14.1	23.0	32	30	U 5/8-11(M16×2)	1.00
	NT40-MTA3-35	3	23.1	32.0	40	45	U 5/8-11(M16×2)	1.00
	NT40-MTA4-90	4	32.1	50.0	50	90	U 5/8-11(M16×2)	1.20
50	NT50-MTA1-30	1	2.0	14.0	25	30	U 1-8(M24×3)	3.50
	NT50-MTA2-30	2	14.1	23.0	32	30	U 1-8(M24×3)	3.50
	NT50-MTA3-30	3	23.1	32.0	40	30	U 1-8(M24×3)	3.50
	NT50-MTA4-45	4	32.1	50.0	50	45	U 1-8(M24×3)	3.50
	NT50-MTA5-105	5	50.1	75.0	60	105	U 1-8(M24×3)	4.00

MORSE TAPER ADAPTER EINSATZHÜLSEN FÜR MORSEKEGEL

DIN69893-HSK FORM A

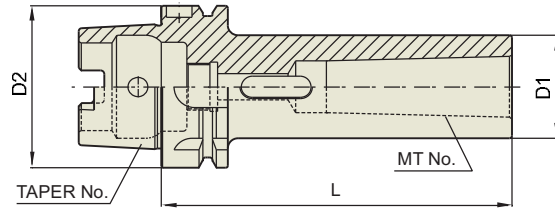

DIN69893 - HSK	Taper Accuracy AT3	G Value	RPM	Coolant System
-------------------	--------------------------	---------	-----	-------------------

TAPER No.	CODE No.	MT No.	D1	D2	L	Weight (kg)
50A	HSK 50A-MTA1-100	1	25	50	100	0.67
	HSK 50A-MTA2-120	2	32	50	120	0.78
	HSK 50A-MTA3-140	3	40	50	140	0.91
63A	HSK 63A-MTA1-100	1	25	63	100	0.87
	HSK 63A-MTA2-120	2	32	63	120	1.28
	HSK 63A-MTA3-140	3	40	63	140	1.44
	HSK 63A-MTA4-160	4	48	63	160	1.86
100A	HSK100A-MTA1-110	1	25	100	110	2.12
	HSK100A-MTA2-120	2	32	100	120	2.41
	HSK100A-MTA3-150	3	40	100	150	2.82
	HSK100A-MTA4-170	4	48	100	170	3.63
	HSK100A-MTA5-200	5	63	100	200	4.80



MORSE TAPER ADAPTER EINSATZHÜLSEN FÜR MORSEKEGEL

TOOL
HOLDERS

DIN69871-SK

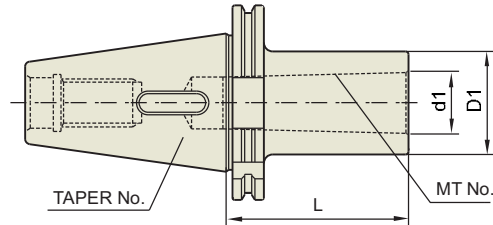

DIN69871
-SK

Taper
Accuracy
AT3

G Value

RPM

Coolant
System

■ STANDARD

TAPER No.	CODE No.	MT No.	d1	D1	L	Weight (kg)
30	SK30-MTA1-50	1	12.065	25	50	0.72
	SK30-MTA2-60	2	17.78	32	60	0.87
	SK30-MTA3-80	3	23.825	40	80	1.02
40	SK40-MTA1-50	1	12.065	25	50	1.49
	SK40-MTA2-50	2	17.78	32	50	1.62
	SK40-MTA3-70	3	23.825	40	70	1.65
	SK40-MTA4-95	4	31.267	48	95	1.90
50	SK50-MTA1-45	1	12.065	25	45	2.60
	SK50-MTA2-60	2	17.78	32	60	2.66
	SK50-MTA3-65	3	23.825	40	65	2.75
	SK50-MTA4-95	4	31.267	48	95	3.00
	SK50-MTA5-105	5	44.399	63	105	3.30

TAPPING ER CHUCK ER - GEWINDESCHNEIDFUTTER

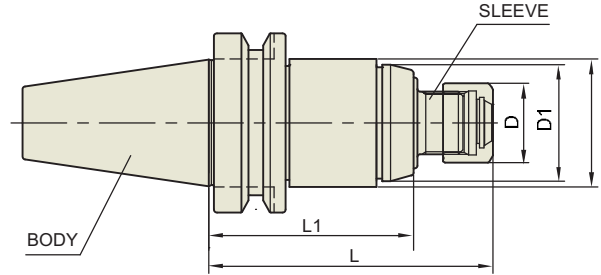
MAS403-BT

MAS403 -BT	Taper Accuracy AT3	G Value	RPM	Coolant System
---------------	--------------------------	---------	-----	-------------------

TAPER No.	CODE No.	D	D1	D2	L	L1	NUT	Weight (kg)
40	BT40-TER16-100	28	41	45	100	68.4	ER16	1.45
	BT40-TER16-150	28	41	45	150	118.4	ER16	2.00
	BT40-TER32-110	50	58	63	110	72	ER32	2.20
	BT40-TER32-150	50	58	63	150	112	ER32	2.70
50	BT50-TER16-115	28	41	45	115	79.4	ER16	3.95
	BT50-TER16-150	28	41	45	150	114.4	ER16	4.35
	BT50-TER32-120	50	58	63	120	83	ER32	4.70
	BT50-TER32-150	50	58	63	150	113	ER32	5.20

► ER collet of page 1118 and 1119, and Tap ER collet of page 1120 are usable.



TAPPING ER CHUCK ER - GEWINDESCHNEIDFUTTER

TOOL
HOLDERS

DIN69893-HSK

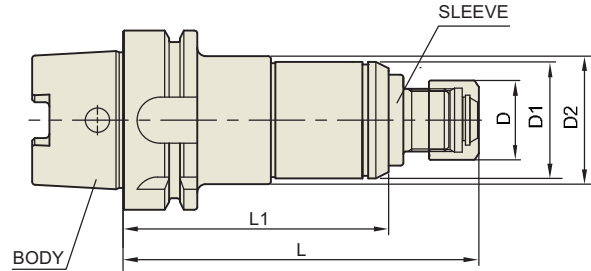

DIN69893 - HSK	Taper Accuracy AT3	G Value	RPM	Coolant System
-------------------	--------------------------	---------	-----	-------------------

TAPER No.	CODE No.	D	D1	D2	L	L1	NUT	Weight (kg)
50	HSK50A-TER16-125	28	41	45	125	93.4	ER16	1.20
	HSK50A-TER16-150	28	41	45	150	118.4	ER16	1.30
63	HSK63A-TER16-125	28	41	45	125	93.4	ER16	1.70
	HSK63A-TER16-150	28	41	45	150	118.4	ER16	1.85
	HSK63A-TER32-150	50	58	63	150	112	ER32	2.10
	HSK63A-TER32-180	50	58	63	180	142	ER32	2.30
100	HSK100A-TER16-130	28	41	45	130	98.4	ER16	4.00
	HSK100A-TER16-150	28	41	45	150	118.4	ER16	4.20
	HSK100A-TER32-150	50	58	63	150	112	ER32	4.40
	HSK100A-TER32-180	50	58	63	180	142	ER32	4.60

► ER collet of page 1118 and 1119, and Tap ER collet of page 1120 are usable.

TAPPING ER CHUCK ER - GEWINDESCHNEIDFUTTER

DIN69871-SK

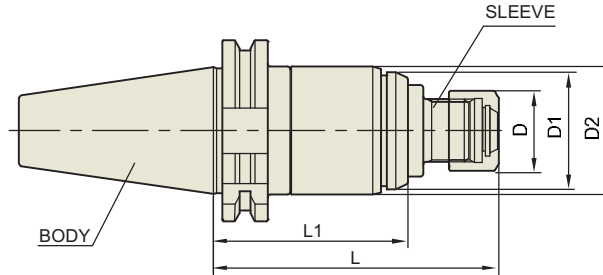

DIN69871 -SK	Taper Accuracy AT3	G Value	RPM	Coolant System
-----------------	--------------------------	---------	-----	-------------------

TAPER No.	CODE No.	D	D1	D2	L	L1	NUT	Weight (kg)
40	SK40-TER16-100	28	41	45	100	68.4	ER16	1.65
	SK40-TER16-150	28	41	45	150	118.4	ER16	1.85
	SK40-TER32-130	50	58	63	130	92	ER32	2.10
	SK40-TER32-150	50	58	63	150	112	ER32	2.30
50	SK50-TER16-115	28	41	45	115	79.4	ER16	4.30
	SK50-TER16-150	28	41	45	150	114.4	ER16	4.50
	SK50-TER32-120	50	58	63	120	83	ER32	4.65
	SK50-TER32-150	50	58	63	150	113	ER32	4.85

► ER collet of page 1118 and 1119, and Tap ER collet of page 1120 are usable.



TAP CHUCK

GEWINDESCHNEID-SCHNELLWECHSELFUTTER

TOOL
HOLDERS

MAS403-BT

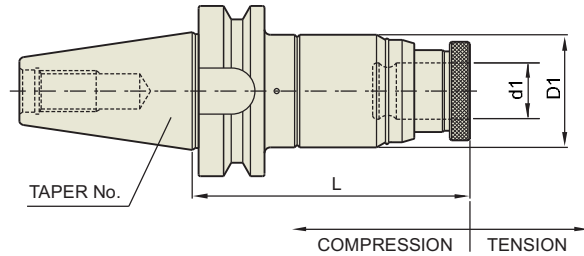

MAS403 -BT	Taper Accuracy AT3	G Value	RPM	Coolant System
---------------	--------------------------	---------	-----	-------------------

TAPER No.	CODE No.	TAP SIZE	LENGTH COMPENSATION		d1	D1	L	TAP ADAPTER CODE	Weight (kg)
			COMP.	TEN.					
30	BT30-TC12-100	M3~M12	5	15	19	45	100	TCS12	1.0
40	BT40-TC12- 90	M3~M12	5	15	19	45	90	TCS12	1.5
	BT40-TC12-130	M3~M12	5	15	19	45	130	TCS12	1.6
	BT40-TC24-100	M6~M24	5	20	31	63	100	TCS24	2.1
	BT40-TC24-142	M6~M24	5	20	31	63	142	TCS24	2.9
50	BT50-TC12-130	M3~M12	5	15	19	45	130	TCS12	4.2
	BT50-TC12-175	M3~M12	5	15	19	45	175	TCS12	4.8
	BT50-TC12-220	M3~M12	5	15	19	45	220	TCS12	5.1
	BT50-TC24-142	M6~M24	5	20	31	63	142	TCS24	5.8
	BT50-TC24-187	M6~M24	5	20	31	63	187	TCS24	6.0
	BT50-TC38-175	M18~M38	10	25	48	98	175	TCS38	8.3

TAP CHUCK - STRAIGHT SHANK GEWINDESCHNEID-SCHNELLWECHSELFUTTER - GERADEAUS SCHAFT

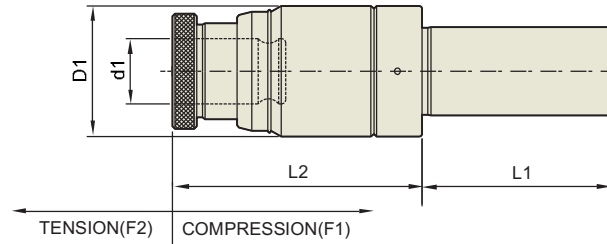

K	Taper Accuracy AT3	G Value	RPM	Coolant System
---	-----------------------	---------	-----	----------------

TAPER No.	CODE No.	TAP SIZE	LENGTH COMPENSATION		d1	D1	L1	L2	TAP ADAPTER CODE	Weight (kg)
			COMP.	TEN.						
32	K32-TC12-100	M3-M12	15	5	32	45	60	100	TCS12	0.90
	K32-TC24-120	M6-M24	20	5	32	63	60	120	TCS24	1.40
42	K42-TC12-100	M3-M12	15	5	42	45	70	100	TCS12	1.10
	K42-TC24-120	M6-M24	20	5	42	63	70	120	TCS24	1.60



TAP CHUCK
GEWINDESCHNEID-SCHNELLWECHSELFUTTER

TOOL
HOLDERS

DIN69893-HSK

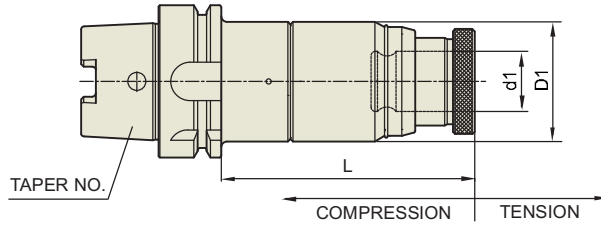

DIN69893
- HSK

Taper
Accuracy
AT3

G Value

RPM

Coolant
System

TAPER No.	CODE No.	TAP SIZE	LENGTH COMPENSATION		d1	D1	L	TAP ADAPTER CODE	Weight (kg)
			COMP.	TEN.					
63A	HSK63A-TC12-120	M3 ~ M12	5	15	19	45	120	TCS12	1.00
	HSK63A-TC12-150	M3 ~ M12	5	15	19	45	150	TCS12	1.70
	HSK63A-TC24-142	M6 ~ M24	5	20	31	63	142	TCS24	2.40
	HSK63A-TC24-172	M6 ~ M24	5	20	31	63	172	TCS24	2.70
100A	HSK100A-TC12-130	M3 ~ M12	5	15	19	45	130	TCS12	4.30
	HSK100A-TC12-175	M3 ~ M12	5	15	19	45	175	TCS12	4.80
	HSK100A-TC12-220	M3 ~ M12	5	15	19	45	220	TCS12	5.30
	HSK100A-TC24-142	M6 ~ M24	5	20	31	63	142	TCS24	5.20
	HSK100A-TC24-187	M6 ~ M24	5	20	31	63	187	TCS24	6.60
	HSK100A-TC38-200	M18 ~ M38	10	25	48	98	200	TCS38	8.00

TAP CHUCK GEWINDESCHNEID-SCHNELLWECHSELFUTTER

DIN69871-SK

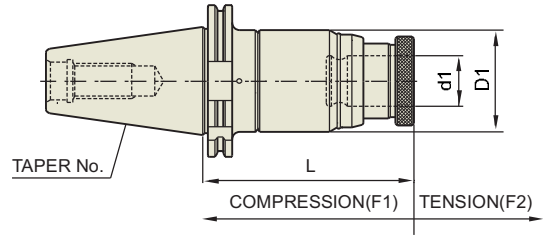

DIN69871 -SK	Taper Accuracy AT3	G Value	RPM	Coolant System
-----------------	-----------------------	---------	-----	----------------

STANDARD

TAPER No.	CODE No.	TAP SIZE	d1	D1	L	F1	F2	Weight (kg)
40	SK40-TC12-90	M3-M12	19	45	90	5	15	1.30
	SK40-TC12-130	M3-M12	19	45	130	5	15	1.80
	SK40-TC24-120	M6-M24	31	63	120	5	20	2.50
	SK40-TC24-142	M6-M24	31	63	142	5	20	2.80
50	SK50-TC12-130	M3-M12	19	45	130	5	15	4.30
	SK50-TC12-175	M3-M12	19	45	175	5	15	5.50
	SK50-TC24-142	M6-M24	31	63	142	5	20	5.30
	SK50-TC24-187	M6-M24	31	63	187	5	20	7.80
	SK50-TC38-175	M18-M38	48	98	175	10	25	7.50

MTA

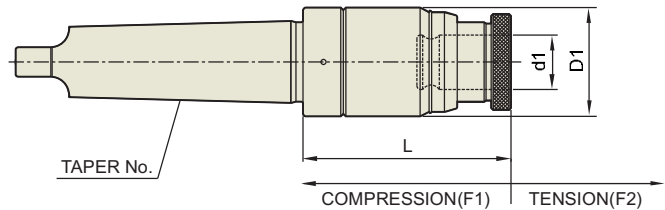

DIN228 -MTA	Taper Accuracy AT3	G Value	RPM	Coolant System
----------------	-----------------------	---------	-----	----------------

TAPER No.	CODE No.	TAP SIZE	LENGTH COMPENSATION		d1	D1	L	TAP ADAPTER CODE	Weight (kg)
			COMP.	TEN.					
3	MTA3-TC12-90	M3-M12	5	15	19	45	90	TCS12	1.00
	MTA3-TC24-115	M6-M24	5	20	31	63	115	TCS24	2.00
4	MTA4-TC12-105	M3-M12	5	15	19	45	105	TCS12	1.20
	MTA4-TC24-115	M6-M24	5	20	31	63	115	TCS24	2.20
5	MTA5-TC12-145	M3-M12	5	15	19	45	145	TCS12	1.50
	MTA5-TC24-175	M6-M24	5	20	31	63	175	TCS24	2.60

TAP ADAPTER SCHNELLWECHSEL-EINSATZ

JIS

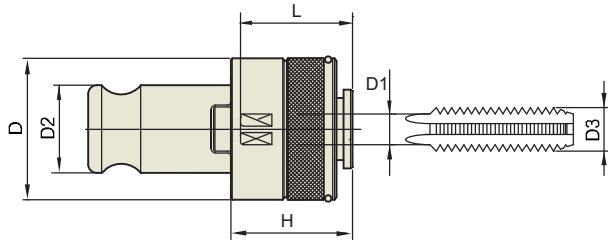

TAPER No.	CODE No.	D	D1	D2	D3	H	W	L	Weight (kg)
TCS12	TCS12-M3	32	4	19	3	25	3.2	24	0.18
	TCS12-M4	32	5	19	4	25	4.	24	0.18
	TCS12-M5	32	5.5	19	5	25	4.5	24	0.18
	TCS12-M6, U1/4	32	6	19	6	25	4.5	24	0.18
	TCS12-M8	32	6.2	19	8	25	5	25	0.18
	TCS12-M10, U3/8	32	7	19	10	25	5.5	25	0.18
	TCS12-M12	32	8.5	19	12	25	6.5	26	0.18
TCS24	TCS24-M6	52	6	31	6	33	4.5	38	0.60
	TCS24-M8	52	6.2	31	8	33	5	38	0.60
	TCS24-M10	52	7	31	10	33	5.5	38	0.60
	TCS24-M12	52	8.5	31	12	33	6.5	39	0.60
	TCS24-M14, U3/4	52	10.5	31	14	33	8	41	0.60
	TCS24-M16	52	12.5	31	16	33	10	43	0.60
	TCS24-M18, P3/8	52	14	31	18	33	11	43	0.60
	TCS24-M20	52	15	31	20	33	12	43.5	0.60
	TCS24-M22, U7/8	52	17	31	22	33	13	46	0.60
	TCS24-M24, PF5/8	52	19	31	24	33	15	46	0.60
TCS38	TCS38-M18	72	14	48	18	45	11	43	1.80
	TCS38-M20	72	15	48	20	45	12	43.5	1.80
	TCS38-M22	72	17	48	22	45	13	45	1.80
	TCS38-M24	72	19	48	24	45	15	45	1.80
	TCS38-M27, U1"	72	20	48	27	45	15	62	1.80
	TCS38-M30, PT3/4	72	23	48	30	45	17	64	1.80
	TCS38-M33	72	25	48	33	45	19	66	1.80
	TCS38-M36	72	28	48	36	45	19	68	1.80
	TCS38-M38	72	28	48	38	45	21	68	1.80

FEATURES

1. Type of built-in torque safety device with rapid exchange mode
2. Tap size (Ø x □) and range designation are needed.

END MILL HOLDER
FRÄSERFUTTER

DIN69871-SK



FIG.1

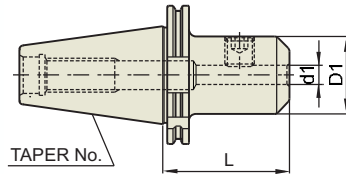
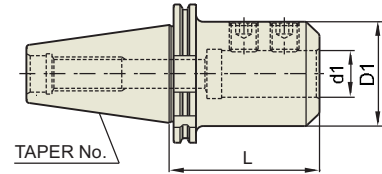

FIG.2



DIN69871
-SK

Taper
Accuracy
AT3

G Value
6.3

RPM
12,000

Coolant
System

■ **STUB**

TAPER No.	CODE No.	d1	D1	L	FIG.	Weight (kg)
40	SK40-EMH16-35	16	44	35	1	0.86
	SK40-EMH20-35	20	44	35	1	0.91
	SK40-EMH25-60	25	50	60	1	0.97

■ **STANDARD**

TAPER No.	CODE No.	d1	D1	L	FIG.	Weight (kg)
30	SK30-EMH6-50	6	25	50	1	0.73
	SK30-EMH8-50	8	28	50	1	0.83
	SK30-EMH10-50	10	35	50	1	0.90
	SK30-EMH12-50	12	42	50	1	0.90
	SK30-EMH16-63	16	48	63	1	1.10
40	SK40-EMH6-50	6	25	50	1	0.86
	SK40-EMH8-50	8	28	50	1	0.89
	SK40-EMH10-50	10	35	50	1	0.95
	SK40-EMH12-50	12	42	50	1	1.03
	SK40-EMH16-63	16	48	63	1	1.26
	SK40-EMH20-63	20	52	63	1	1.28
	SK40-EMH25-100	25	65	100	2	2.28
50	SK40-EMH32-100	32	72	100	2	2.50
	SK50-EMH6-63	6	25	63	1	2.70
	SK50-EMH8-63	8	28	63	1	2.70
	SK50-EMH10-63	10	35	63	1	2.90
	SK50-EMH12-63	12	42	63	1	2.90
	SK50-EMH16-63	16	48	63	1	3.00
	SK50-EMH20-63	20	52	63	1	3.05
	SK50-EMH25-80	25	65	80	2	3.73
	SK50-EMH32-100	32	72	100	2	4.53
	SK50-EMH40-100	40	80	100	2	4.77
SK50-EMH50-100	50	98	120	2	7.03	

► Higher balancing grade product could be supplied by customer's request.

**END MILL HOLDER
FRÄSERFUTTER**

 TOOL
HOLDERS

DIN69871-SK FORM AD/B

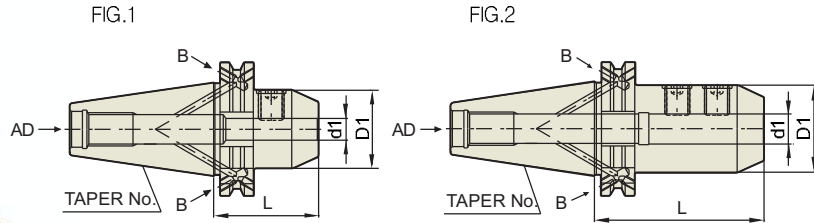

DIN69871 -SK	Taper Accuracy AT3	G Value 6.3	RPM 12,000	Coolant System AD/B
-----------------	--------------------------	----------------	---------------	---------------------------

STANDARD

TAPER No.	CODE No.	d1	D1	L	FIG.	Weight (kg)
40	SK40AD/B-EMH6-50	6	25	50	1	0.86
	SK40AD/B-EMH8-50	8	28	50	1	0.89
	SK40AD/B-EMH10-50	10	35	50	1	0.95
	SK40AD/B-EMH12-50	12	42	50	1	1.03
	SK40AD/B-EMH16-63	16	48	63	1	1.26
	SK40AD/B-EMH20-63	20	52	63	1	1.28
	SK40AD/B-EMH25-100	25	65	100	2	2.29
	SK40AD/B-EMH32-100	32	72	100	2	2.50
50	SK50AD/B-EMH6-63	6	25	63	1	2.70
	SK50AD/B-EMH8-63	8	28	63	1	2.70
	SK50AD/B-EMH10-63	10	35	63	1	2.90
	SK50AD/B-EMH12-63	12	42	63	1	2.90
	SK50AD/B-EMH16-63	16	48	63	1	3.00
	SK50AD/B-EMH20-63	20	52	63	1	3.05
	SK50AD/B-EMH25-80	25	65	80	1	3.73
	SK50AD/B-EMH32-100	32	72	100	1	4.53
	SK50AD/B-EMH40-100	40	80	100	1	4.77
	SK50AD/B-EMH50-100	50	98	100	1	7.03

▶ Higher balancing grade product could be supplied by customer's request.

END MILL HOLDER (SPRAY NOZZLE) FRÄSERFUTTER (SPRAYDÜSE)

DIN 69871 - SK FORM AD/B

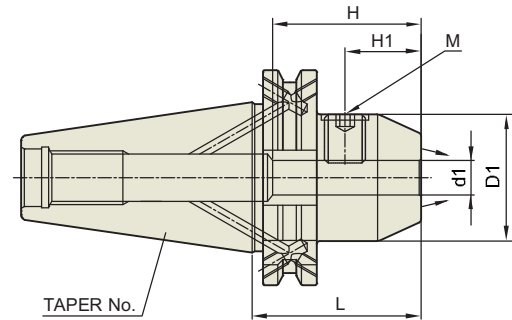

DIN69871 -SK	Taper Accuracy AT3	G Value 6.3	RPM 12,000	Coolant System AD/B
-----------------	--------------------------	----------------	---------------	---------------------------

TAPER No.	CODE No.	d1	D1	L	H	H1	M	Weight (kg)
40	SK40AD/B-EMH6C-50	6	25	50	35	18	M6	0.86
	SK40AD/B-EMH8C-50	8	28	50	35	18	M8	0.89
	SK40AD/B-EMH10C-50	10	35	50	35.5	20	M10	0.95
	SK40AD/B-EMH12C-50	12	42	50	36	22.5	M12	1.03
	SK40AD/B-EMH14C-50	14	44	50	36	22.5	M12	1.26
	SK40AD/B-EMH16C-63	16	48	63	46	24	M14	1.28
	SK40AD/B-EMH18C-63	18	50	63	46	24	M14	1.35
	SK40AD/B-EMH20C-63	20	52	63	48	25	M16	1.40
	SK40AD/B-EMH25C-100	25	65	100	55	25	M18	2.29
SK40AD/B-EMH32C-100	32	72	100	57	28	M20	2.50	
50	SK50AD/B-EMH6C-63	6	25	63	35	18	M6	2.70
	SK50AD/B-EMH8C-63	8	28	63	35	18	M8	2.70
	SK50AD/B-EMH10C-63	10	35	63	35.5	20	M10	2.90
	SK50AD/B-EMH12C-63	12	42	63	36	22.5	M12	2.90
	SK50AD/B-EMH14C-63	14	44	63	36	22.5	M12	3.00
	SK50AD/B-EMH16C-63	16	48	63	46	24	M14	3.00
	SK50AD/B-EMH18C-63	18	50	63	46	24	M14	3.00
	SK50AD/B-EMH20C-63	20	52	63	48	25	M16	3.05
	SK50AD/B-EMH25C-80	25	65	80	55	25	M18	3.73
	SK50AD/B-EMH32C-100	32	72	100	57	28	M20	4.53
SK50AD/B-EMH40C-120	40	90	120	68	32	M20	4.80	

► Higher balancing grade product could be supplied by customer's request.



END MILL HOLDER FRÄSERFUTTER

TOOL
HOLDERS

DIN69893-HSK FORM A

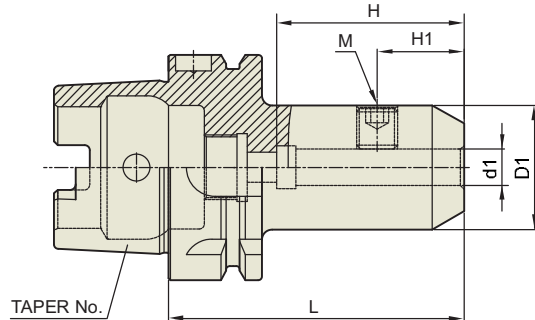

DIN69893
- HSK

Taper
Accuracy
AT3

G Value
6.3

RPM
12,000

Coolant
System

TAPER No.	CODE No.	d1	D1	L	H	H1	M	Weight (kg)
40A	HSK40A-EMH6-60	6	25	60	35	18	M6	0.30
	HSK40A-EMH8-60	8	28	60	35	18	M8	0.30
	HSK40A-EMH10-60	10	35	60	35.5	20	M10	0.30
	HSK40A-EMH12-70	12	42	70	36	22.5	M12	0.40
	HSK40A-EMH14-70	14	44	70	36	22.5	M12	0.40
	HSK40A-EMH16-80	16	48	80	46	24	M14	0.60
50A	HSK50A-EMH6-65	6	25	65	35	18	M6	0.70
	HSK50A-EMH8-65	8	28	65	35	18	M8	0.80
	HSK50A-EMH10-65	10	35	65	35.5	20	M10	0.80
	HSK50A-EMH12-80	12	42	80	36	22.5	M12	1.20
	HSK50A-EMH14-80	14	44	80	36	22.5	M12	1.30
	HSK50A-EMH16-80	16	48	80	46	24	M14	1.30
	HSK50A-EMH18-80	18	50	80	46	24	M14	1.40
	HSK50A-EMH20-80	20	52	80	48	25	M16	1.50
63A	HSK63A-EMH6-65	6	25	65	35	18	M6	0.80
	HSK63A-EMH8-65	8	28	65	35	18	M8	0.80
	HSK63A-EMH10-65	10	35	65	35.5	20	M10	0.90
	HSK63A-EMH12-80	12	42	80	36	22.5	M12	1.10
	HSK63A-EMH14-80	14	44	80	36	22.5	M12	1.20
	HSK63A-EMH16-80	16	48	80	46	24	M14	1.30
	HSK63A-EMH18-80	18	50	80	46	24	M14	1.40
	HSK63A-EMH20-80	20	52	80	48	25	M16	1.50
	HSK63A-EMH25-110	25	65	110	55	25	M18	2.30
	HSK63A-EMH32-110	32	72	110	57	28	M20	2.60
100A	HSK100A-EMH6-80	6	25	80	35	18	M6	2.15
	HSK100A-EMH8-80	8	28	80	35	18	M8	2.20
	HSK100A-EMH10-80	10	35	80	35.5	20	M10	2.35
	HSK100A-EMH12-80	12	42	80	36	22.5	M12	2.45
	HSK100A-EMH14-80	14	44	80	36	22.5	M12	2.65
	HSK100A-EMH16-100	16	48	100	46	24	M14	2.85
	HSK100A-EMH18-100	18	50	100	46	24	M14	2.90
	HSK100A-EMH20-100	20	52	100	48	25	M16	2.95
	HSK100A-EMH25-100	25	65	100	55	25	M18	3.45
	HSK100A-EMH32-100	32	72	100	57	28	M20	3.65
	HSK100A-EMH40-120	40	90	120	68	32	M20	5.50

END MILL HOLDER (SPRAY NOZZLE) FRÄSERFUTTER (SPRAYDÜSE)

DIN69893-HSK FORM A

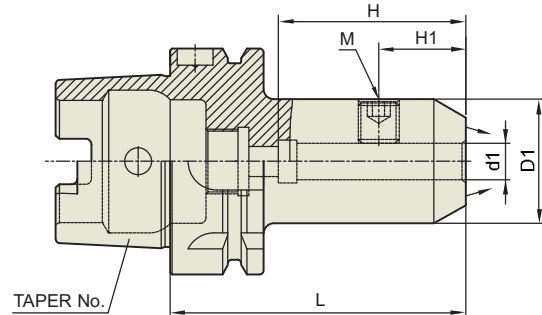

DIN69893
- HSK

Taper
Accuracy
AT3

G Value
6.3

RPM
12,000

Coolant
System

TAPER No.	CODE No.	d1	D1	L	H	H1	M	Weight (kg)
40A	HSK40A-EMH6C-60	6	25	60	35	18	M6	0.30
	HSK40A-EMH8C-60	8	28	60	35	18	M8	0.30
	HSK40A-EMH10C-60	10	35	60	35.5	20	M10	0.30
	HSK40A-EMH12C-70	12	42	70	36	22.5	M12	0.40
	HSK40A-EMH14C-70	14	44	70	36	22.5	M12	0.40
	HSK40A-EMH16C-80	16	48	80	46	24	M14	0.60
50A	HSK50A-EMH6C-65	6	25	65	35	18	M6	0.70
	HSK50A-EMH8C-65	8	28	65	35	18	M8	0.80
	HSK50A-EMH10C-65	10	35	65	35.5	20	M10	0.80
	HSK50A-EMH12C-80	12	42	80	36	22.5	M12	1.20
	HSK50A-EMH14C-80	14	44	80	36	22.5	M12	1.30
	HSK50A-EMH16C-80	16	48	80	46	24	M14	1.30
	HSK50A-EMH18C-80	18	50	80	46	24	M14	1.40
	HSK50A-EMH20C-80	20	52	80	48	25	M16	1.50
63A	HSK63A-EMH6C-65	6	25	65	35	18	M6	0.80
	HSK63A-EMH8C-65	8	28	65	35	18	M8	0.80
	HSK63A-EMH10C-65	10	35	65	35.5	20	M10	0.90
	HSK63A-EMH12C-80	12	42	80	36	22.5	M12	1.10
	HSK63A-EMH14C-80	14	44	80	36	22.5	M12	1.20
	HSK63A-EMH16C-80	16	48	80	46	24	M14	1.30
	HSK63A-EMH18C-80	18	50	80	46	24	M14	1.40
	HSK63A-EMH20C-80	20	52	80	48	25	M16	1.50
	HSK63A-EMH25C-110	25	65	110	55	25	M18	2.30
	HSK63A-EMH32C-110	32	72	110	57	28	M20	2.60
100A	HSK100A-EMH6C-80	6	25	80	35	18	M6	2.15
	HSK100A-EMH8C-80	8	28	80	35	18	M8	2.20
	HSK100A-EMH10C-80	10	35	80	35.5	20	M10	2.35
	HSK100A-EMH12C-80	12	42	80	36	22.5	M12	2.45
	HSK100A-EMH14C-80	14	44	80	36	22.5	M12	2.65
	HSK100A-EMH16C-100	16	48	100	46	24	M14	2.85
	HSK100A-EMH18C-100	18	50	100	46	24	M14	2.90
	HSK100A-EMH20C-100	20	52	100	48	25	M16	2.95
	HSK100A-EMH25C-100	25	65	100	55	25	M18	3.45
	HSK100A-EMH32C-100	32	72	100	57	28	M20	3.65
	HSK100A-EMH40C-120	40	90	120	68	32	M20	5.50



**END MILL HOLDER (SPRAY NOZZLE)
FRÄSERFUTTER (SPRAYDÜSE)**

TOOL
HOLDERS

MAS403-BT FORM AD/B

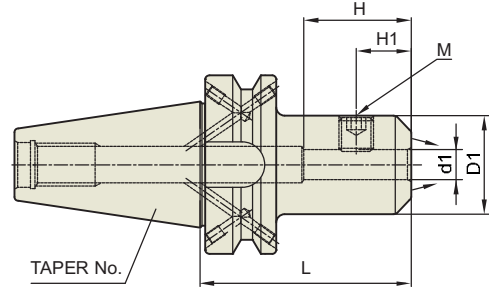

MAS403 -BT	Taper Accuracy AT3	G Value 6.3	RPM 12,000	Coolant System
---------------	--------------------------	----------------	---------------	-------------------

TAPER No.	CODE No.	d1	D1	L	H	H1	M	Weight (kg)
40	BT40-EMH6C-50	6	25	50	35	18	M6	1.00
	BT40-EMH8C-50	8	28	50	35	18	M8	1.00
	BT40-EMH10C-63	10	35	63	35.5	20	M10	1.10
	BT40-EMH12C-63	12	42	63	36	22.5	M12	1.30
	BT40-EMH14C-63	14	44	63	36	22.5	M12	1.40
	BT40-EMH16C-63	16	48	63	46	24	M14	1.70
	BT40-EMH18C-63	18	50	63	46	24	M14	1.70
	BT40-EMH20C-63	20	52	63	48	25	M16	1.80
	BT40-EMH25C-90	25	65	90	55	25	M18	1.80
BT40-EMH32C-100	32	72	100	57	28	M20	2.00	
50	BT50-EMH6C-63	6	25	63	35	18	M6	3.30
	BT50-EMH8C-63	8	28	63	35	18	M8	3.60
	BT50-EMH10C-65	10	35	65	35.5	20	M10	3.80
	BT50-EMH12C-80	12	42	80	36	22.5	M12	3.80
	BT50-EMH14C-80	14	44	80	36	22.5	M12	4.00
	BT50-EMH16C-80	16	48	80	46	24	M14	4.00
	BT50-EMH18C-80	18	50	80	46	24	M14	4.20
	BT50-EMH20C-80	20	52	80	48	25	M16	4.20
	BT50-EMH25C-100	25	65	100	55	25	M18	4.60
BT50-EMH32C-105	32	72	105	57	28	M20	4.70	
BT50-EMH40C-120	40	90	120	68	32	M20	4.90	

► Higher balancing grade product could be supplied by customer's request.

SIDE LOCK ARBOR FLÄCHENSPIANNFUTTER

MAS403-BT

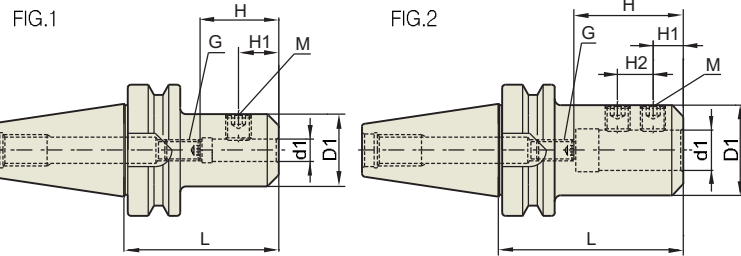

MAS403-BT	Taper Accuracy AT3	G Value 6.3	RPM 12,000	Coolant System
-----------	-----------------------	----------------	---------------	----------------

TAPER No.	CODE No.	d1	L	D1	H		H1	H2	M	G	Weight (kg)
					MIN	MAX					
30	BT30-SLA 6-60	6	60	25	20	35	18	-	M5	M5	0.7
	BT30-SLA 8-60	8	60	28	20	35	18	-	M6	M6	0.8
	BT30-SLA10-60	10	60	35	35	50	14	13	M8	M8	0.9
	BT30-SLA12-60	12	60	40	35	50	14	13	M10	M10	1.1
	BT30-SLA14-60	14	60	40	35	50	14	13	M10	M10	1.2
	BT30-SLA16-75	16	75	40	55	70	25	20	M12	M12	1.3
	BT30-SLA20-75	20	75	50	55	70	25	20	M12	M12	1.4
	BT30-SLA25-75	25	75	50	55	70	25	20	M14	M12	1.5
40	BT30-SLA32-105	32	105	60	65	80	30	20	M16	M12	1.6
	BT40-SLA 6-60	6	60	25	20	35	18	-	M5	M5	1.1
	BT40-SLA 8-60	8	60	28	20	35	18	-	M6	M6	1.1
	BT40-SLA10-60	10	60	35	35	50	14	13	M8	M8	1.2
	BT40-SLA12-60	12	60	40	35	50	14	13	M10	M10	1.4
	BT40-SLA16-90	16	90	40	55	70	25	20	M12	M12	1.5
	BT40-SLA20-90	20	90	50	55	70	25	20	M12	M12	1.8
	BT40-SLA25-90	25	90	50	55	70	25	20	M14	M12	1.7
	BT40-SLA32-90	32	90	60	65	80	30	20	M16	M12	1.9
50	BT40-SLA40-90	40	90	70	65	80	30	20	M16	M12	1.8
	BT40-SLA42-90	42	90	70	65	80	30	20	M16	M12	1.8
	BT50-SLA 6-90	6	90	25	25	40	18	-	M5	M5	3.7
	BT50-SLA 8-90	8	90	28	25	40	18	-	M6	M6	3.9
	BT50-SLA10-90	10	90	35	35	50	15	15	M8	M8	4.1
	BT50-SLA12-90	12	90	40	40	55	15	15	M10	M10	4.3
	BT50-SLA14-90	14	90	40	40	55	15	15	M10	M10	4.3
	BT50-SLA16-105	16	105	40	55	70	25	20	M12	M12	4.4
	BT50-SLA20-105	20	105	50	55	70	25	20	M12	M12	4.8
	BT50-SLA25-105	25	105	50	55	70	25	20	M14	M12	4.7
	BT50-SLA32-105	32	105	60	65	80	25	25	M16	M12	4.0
BT50-SLA40-105	40	105	70	65	80	25	25	M16	M12	4.5	
BT50-SLA42-105	42	105	70	65	80	25	25	M16	M12	4.7	
BT50-SLA50.8-121	50.8	121	95	-	87	34	36	M20	-	5.0	

SIDE LOCK ARBOR FLÄCHENSPIANNFUTTER

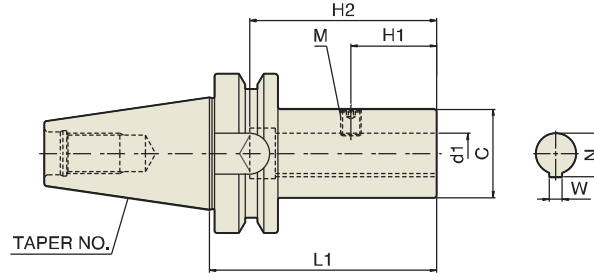
MAS403-BT

MAS403-BT	Taper Accuracy AT3	G Value	RPM	Coolant System
-----------	-----------------------	---------	-----	----------------

TAPER No.	CODE No.	d1	D1	L1	H1	H2	M	W	N	Weight (kg)
40	BT40-SLB26-105	26	50	105	40	85	M10	5	28.2	1.3
	BT40-SLB35-135	35	60	135	55	105	M10	6	37.6	2.2
	BT40-SLB35T-135	35	60	135	55	105	M10	7	38.2	2.2
50	BT50-SLB26-105	26	50	105	40	85	M10	5	28.2	4.4
	BT50-SLB35-135	35	60	135	55	106	M10	6	37.6	4.7
	BT50-SLB35T-135	35	60	135	55	106	M10	7	38.2	4.7
	BT50-SLB48-165	48	80	165	65	129	M10	8	51.0	6.5

SCREW FOR SIDE LOCK ARBOR

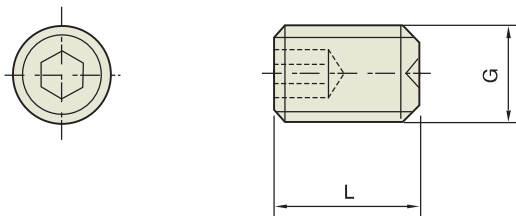

Taper Accuracy AT3	G Value	RPM	Coolant System
-----------------------	---------	-----	----------------

CODE No.	G	L	HOLDER SIZE	Weight (kg)
M5×08 SL	M5×0.8	8	SLA6	
M6×10 SL	M6×1.0	10	SLA8	
M8×10 SL	M8×1.25	10	SLA10	
M10×12 SL	M10×1.5	12	SLA12/SLA14	
M12×16 SL	M12×1.75	16	SLA16/SLA20	
M14×16 SL	M14×2.0	16	SLA25	
M16×16 SL	M16×2.0	16	SLA32/SLA40/SLA42	
M20×25 SL	M20×2.5	25	SLA50.8	

FACE MILL ARBOR AUFNAHMEDORN FÜR MESSERKÖPFE

MAS403-BT



FIG.1

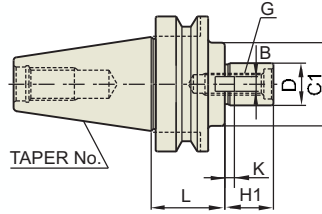
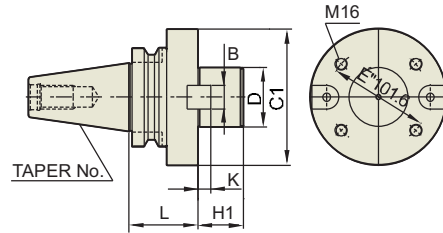

FIG.2



MAS403 -BT	Taper Accuracy AT3	G Value	RPM	Coolant System
---------------	--------------------------	---------	-----	-------------------

TAPER No.	CODE No.	D	L1	C1	H1	B	K	G	FIG.	Weight (kg)
30	BT30-FMA25.4 -45	25.4	45	50	22	9.5	5	M12	1	1.1
	BT30-FMA31.75-45	31.75	45	60	30	12.7	7	M16	1	1.2
40	BT40-FMA25.4 -45	25.4	45	50	22	9.5	5	M12	1	1.5
	BT40-FMA25.4 -90	25.4	90	50	22	9.5	5	M12	1	3.1
	BT40-FMA31.75-45	31.75	45	60	30	12.7	7	M16	1	1.9
	BT40-FMA31.75-75	31.75	75	60	30	12.7	7	M16	1	2.7
	BT40-FMA38.1 -60	38.1	60	80	34	15.9	9	M20	1	2.9
50	BT50-FMA25.4 -45	25.4	45	50	22	9.5	5	M12	1	3.7
	BT50-FMA25.4 -90	25.4	90	50	22	9.5	5	M12	1	4.6
	BT50-FMA25.4 -150	25.4	150	50	22	9.5	5	M12	1	5.5
	BT50-FMA31.75-45	31.75	45	60	30	12.7	7	M16	1	4.5
	BT50-FMA31.75-75	31.75	75	60	30	12.7	7	M16	1	5.3
	BT50-FMA31.75-105	31.75	105	60	30	12.7	7	M16	1	5.8
	BT50-FMA31.75-150	31.75	150	60	30	12.7	7	M16	1	6.3
	BT50-FMA38.1 -45	38.1	45	80	34	15.9	9	M20	1	4.3
	BT50-FMA38.1 -75	38.1	75	80	34	15.9	9	M20	1	5.6
	BT50-FMA38.1 -105	38.1	105	80	34	15.9	9	M20	1	6.0
BT50-FMA38.1 -150	38.1	150	80	34	15.9	9	M20	1	6.5	
	BT50-FMA50.8 -45	50.8	45	100	36	19.05	10	M24	1	4.9
	BT50-FMA50.8 -75	50.8	75	100	36	19.05	10	M24	1	6.8
	BT50-FMA47.625-75	47.625	75	128.57	38	25.4	12.5	-	2	7.7

SPARE PARTS

TYPE	KEY	KEY BOLT	MOUNTING BOLT			
3R(FMA 25.4)						
4R(FMA 31.75)				W9.52	M4×10	MB12
5R(FMA 38.1)				W12.7	M5×12	MB16
6R(FMA 50.8)				W15.87	M6×16	MB20
8R(FMA 47.625)				W19	M6×18	MB24
	-	-	-			



FACE MILL ARBOR AUFNAHMEDORN FÜR MESSERKÖPFE

TOOL
HOLDERS

DIN 2080-NT

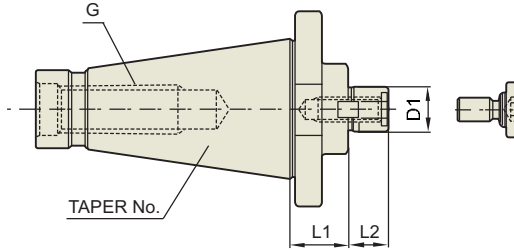

DIN2080 -NT	Taper Accuracy AT3	G Value	RPM	Coolant System
----------------	--------------------------	---------	-----	-------------------

TAPER No.	CODE No.	CUTTER Ø	D1	L1	L2	DRAW THREAD	Old Code No.	Weight (kg)
40	NT40-FMA25.4	3" (75Ø)	25.4	30	22	U5/8-11(M16×2)	NT40-3R	1.45
	NT40-FMA31.75	4" (100Ø)	31.75	30	30	U5/8-11(M16×2)	NT40-4R	1.75
	NT40-FMA38.1	5" (125Ø)	38.1	30	34	U5/8-11(M16×2)	NT40-5R	1.93
	NT40-FMA50.8	6" (150Ø)	50.8	30	36	U5/8-11(M16×2)	NT40-6R	2.55
50	NT50-FMA25.4	3" (75Ø)	25.4	30	22	U1-8(M24×3)	NT50-3R	3.30
	NT50-FMA31.75	4" (100Ø)	31.75	30	30	U1-8(M24×3)	NT50-4R	3.40
	NT50-FMA38.1	5" (125Ø)	38.1	30	34	U1-8(M24×3)	NT50-5R	3.60
	NT50-FMA50.8	6" (150Ø)	50.8	30	36	U1-8(M24×3)	NT50-6R	3.90
	NT50-FMA47.625	8" (200Ø)	47.625	45	38	U1-8(M24×3)	NT50-8R	4.90

MT

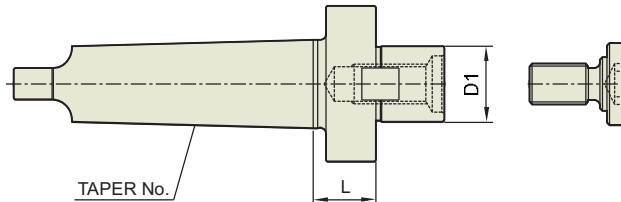

DIN228 -MTA	Taper Accuracy AT3	G Value	RPM	Coolant System
----------------	--------------------------	---------	-----	-------------------

TAPER No.	CODE No.	CUTTER Ø	D1	L	Weight (kg)
5	MT5-FMA25.4	3" (75Ø)	40	22	1.60
	MT5-FMA31.75	4" (100Ø)	41.5	30	1.90
	MT5-FMA38.1	5" (125Ø)	45	34	2.20
6	MT6-FMA25.4	3" (75Ø)	45	22	3.50
	MT6-FMA31.75	4" (100Ø)	45	30	3.80
	MT6-FMA38.1	5" (125Ø)	45	34	4.10
	MT6-FMA50.8	6" (150Ø)	45	36	4.60
	MT6-FMA47.625	8" (200Ø)	48	38	5.40

FACE MILL ARBOR AUFNAHMEDORN FÜR MESSERKÖPFE

MAS403-BT

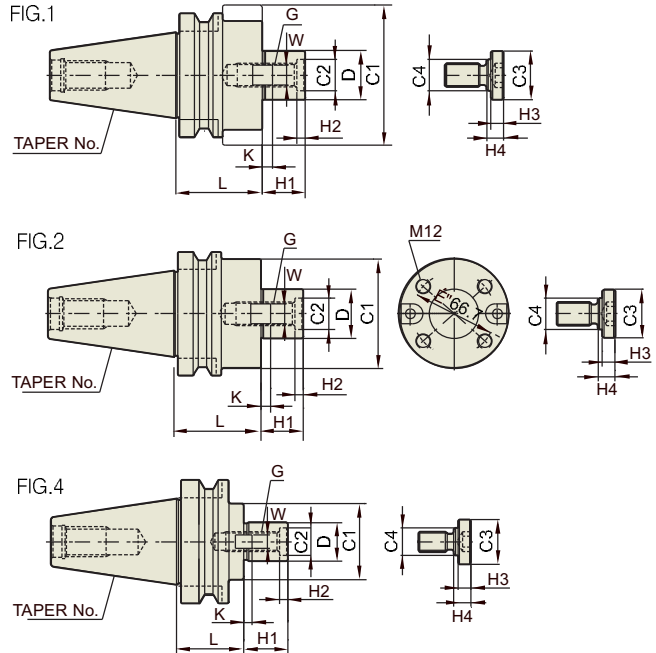

MAS403 -BT	Taper Accuracy AT3	G Value	RPM	Coolant System
---------------	--------------------------	---------	-----	-------------------

■ METRIC TYPE

TAPER No.	CODE No.	FIG.	D	L	C1	C2	H1	H2	W	K	G	C3	C4	H3	H4	Weight (kg)
30	BT30-FMB27- 40	4	27	40	80	-	26	-	12	6	M12	33	23	10	10	2.1
	BT40-FMB27- 60	4	27	60	80	-	26	-	12	6	M12	33	23	10	10	2.5
40	BT40-FMB27- 90	4	27	90	80	-	26	-	12	6	M12	33	23	10	10	4.7
	BT40-FMB40- 60	4	40	60	85	28	26	6	16	8.5	M20	50	27	14	20	7.4
50	BT50-FMB27- 45	1	27	45	80	-	26	-	12	6	M12	33	23	10	12	4.0
	BT50-FMB27- 90	1	27	90	80	-	26	-	12	6	M12	33	23	10	12	5.8
	BT50-FMB27-150	1	27	150	80	-	26	-	12	6	M12	33	23	10	12	8.2
	BT50-FMB40- 45	1	40	45	85	28	26	6	16	8.5	M20	50	27	14	20	4.7
	BT50-FMB40- 75	1	40	75	85	28	26	6	16	8.5	M20	50	27	14	20	6.1
	BT50-FMB40- 105	1	40	105	85	28	26	6	16	8.5	M20	50	27	14	20	8.1
	BT50-FMB40F-75	2	40	75	110	28	26	6	16	8.5	M20	50	27	14	20	6.6
BT50-FMB60- 75	3	60	75	140	-	25	-	25.4	12.5	-	-	-	-	-	7.9	

■ INCH TYPE

TAPER No.	CODE No.	FIG.	D	L	C1	C2	H1	H2	W	K	G	C3	C4	H3	H4	Weight (kg)
30	BT30-FMB25.4-40	4	25.4	40	80	-	26	-	9.5	5	M12	33	23	10	12	2.1
	BT40-FMB25.4-60	4	25.4	60	80	-	26	-	9.5	5	M12	33	23	10	12	2.5
40	BT40-FMB25.4-90	4	25.4	90	80	-	26	-	9.5	5	M12	33	23	10	12	4.7
	BT40-FMB38.1-60	4	38.1	60	85	28	26	6	15.9	9	M20	60	27	14	20	7.4
50	BT50-FMB25.4-45	1	25.4	45	80	-	26	-	9.5	5	M12	33	23	10	12	4.0
	BT50-FMB25.4-90	1	25.4	90	80	-	26	-	9.5	5	M12	33	23	10	12	5.8
	BT50-FMB25.4-150	1	25.4	150	80	-	26	-	9.5	5	M12	33	23	10	12	8.2
	BT50-FMB38.1-45	1	38.1	45	85	28	26	6	15.9	9	M20	50	27	14	20	4.7
	BT50-FMB38.1-75	1	38.1	75	85	28	26	6	15.9	9	M20	50	27	14	20	6.1
	BT50-FMB38.1-105	1	38.1	105	85	28	26	6	15.9	9	M20	50	27	14	20	8.7
	BT50-FMB38.1F-75	2	38.1	75	110	28	26	6	15.9	9	M20	50	27	14	20	6.6

FACE MILL ARBOR
AUFNAHMEDORN FÜR MESSERKÖPFE

 TOOL
HOLDERS

MAS403-BT



FIG.1

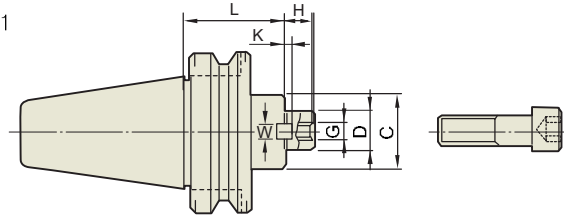
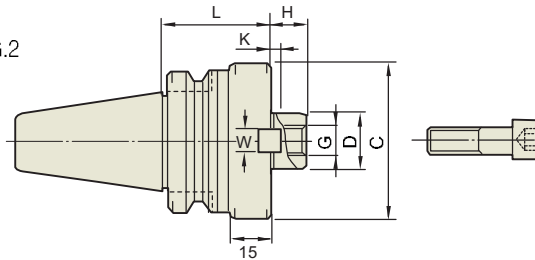

FIG.2

 MAS403
-BT

 Taper
Accuracy
AT3

G Value

RPM

 Coolant
System

METRIC TYPE

TAPER No.	CODE No.	D	L	C	H	W	K	G	FIG.	Weight (kg)
30	BT30-FMC22- 45	22	45	45	18	10	5	M10	2	0.8
40	BT40-FMC22- 45	22	45	45	18	10	5	M10	1	1.3
	BT40-FMC27- 60	27	60	70	20	12	6	M12	2	1.5
	BT40-FMC32- 60	32	60	85	22	14	7	M16	2	2.3
50	BT50-FMC22- 60	22	60	45	18	10	5	M10	1	4.2
	BT50-FMC22-105	22	105	45	18	10	5	M10	1	4.7
	BT50-FMC22-150	22	150	45	18	10	5	M10	1	5.3
	BT50-FMC27- 45	27	45	70	20	12	6	M12	1	4.1
	BT50-FMC27- 90	27	90	70	20	12	6	M12	1	5.5
	BT50-FMC27-150	27	150	70	20	12	6	M12	1	7.3
	BT50-FMC32- 60	32	60	85	22	14	7	M16	1	4.2
	BT50-FMC32-105	32	105	85	22	14	7	M16	1	5.5
	BT50-FMC32-150	32	150	85	22	14	7	M16	1	7.0

INCH TYPE

TAPER No.	CODE No.	D	L	C	H	W	K	G	FIG.	Weight (kg)
30	BT30-FMC25.4- 45	25.4	45	70	20	9.5	6	M12	2	1.1
40	BT40-FMC25.4- 60	25.4	60	70	20	9.5	6	M12	2	1.5
	BT40-FMC25.4- 90	25.4	90	70	20	9.5	6	M12	2	2.2
	BT40-FMC38.1- 60	38.1	60	85	22	15.9	7	M16	2	2.3
	BT40-FMC38.1- 75	38.1	75	85	22	15.9	7	M16	2	2.6
50	BT50-FMC25.4- 45	25.4	45	70	20	9.5	6	M12	1	4.1
	BT50-FMC25.4- 90	25.4	90	70	20	9.5	6	M12	1	5.5
	BT50-FMC25.4-150	25.4	150	70	20	9.5	6	M12	1	7.3
	BT50-FMC38.1- 45	38.1	45	85	22	15.9	7	M16	1	4.2
	BT50-FMC38.1- 75	38.1	75	85	22	15.9	7	M16	1	5.5
	BT50-FMC38.1-105	38.1	105	85	22	15.9	7	M16	1	7.0

SPARE PARTS

TYPE	KEY	KEY BOLT	CLAMP BOLT			
FMC 22						
FMC 27				W10	M4 × 10	M10
FMC 32				W12	M5 × 12	M12
	W14	M6 × 16	M16			

FACE MILL ARBOR AUFNAHMEDORN FÜR MESSERKÖPFE

DIN69893-HSK FORM A

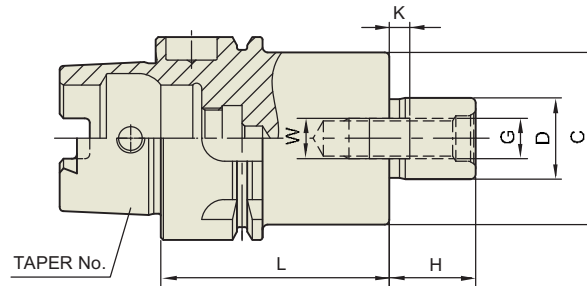

DIN69893 - HSK	Taper Accuracy AT3	G Value	RPM	Coolant System
-------------------	--------------------------	---------	-----	-------------------

TAPER No.	CODE No.	D	C	L	H	W	K	G	Weight (kg)
40A	HSK40A-FMC16-45	16	34	45	17	8	4	M8	0.40
	HSK40A-FMC22-50	22	45	50	18	10	5	M10	0.50
	HSK40A-FMC27-60	27	68	60	20	12	7	M12	0.70



SHELL MILL ARBOR

AUFNAHMEDORN FÜR FRÄSER MIT BOHRUNG

TOOL
HOLDERS

MAS403-BT



FIG.1

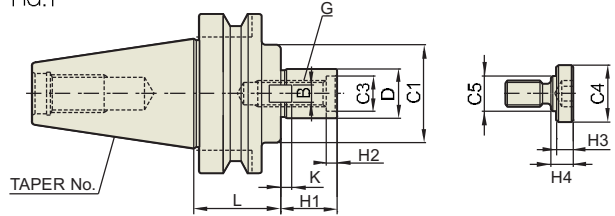
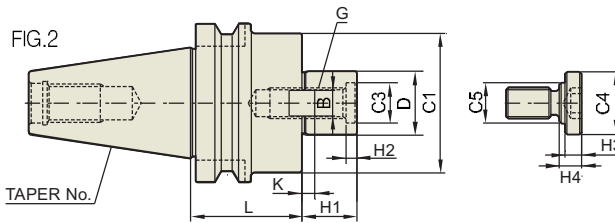

FIG.2



MAS403 -BT	Taper Accuracy AT3	G Value 6.3	RPM 12,000	Coolant System
---------------	--------------------------	----------------	---------------	-------------------

TAPER No.	CODE No.	FIG.	D	L	C1	C2	C3	H1	H2	B	K	G	C4	C5	H3	H4	Weight (kg)
30	BT30-SMA16-30	1	16	30	38	-	-	17	-	8	3	M8	20	15	7	9	0.9
	BT30-SMA22-30	1	22	30	42	-	-	27	-	8	3.5	M10	28	18	9	11	1.0
40	BT40-SMA16-60	1	16	60	38	-	-	17	-	8	3	M8	20	15	7	9	1.3
	BT40-SMA16-120	1	16	120	38	-	-	17	-	8	3	M8	20	15	7	9	1.7
	BT40-SMA22-60	1	22	60	42	-	-	27	-	8	3.5	M10	28	18	9	11	1.4
	BT40-SMA22-120	1	22	120	42	-	-	27	-	8	3.5	M10	28	18	9	11	2.1
	BT40-SMA27-45	2	27	45	50	-	-	36	-	10	4	M12	33	23	10	12	1.4
	BT40-SMA27-105	2	27	105	50	-	-	36	-	10	4	M12	33	23	10	12	2.3
	BT40-SMA32-45	2	32	45	60	-	-	38	-	10	4.5	M16	40	23	10	16	1.6
	BT40-SMA32-75	2	32	75	60	-	-	38	-	10	4.5	M16	40	23	10	16	2.3
	BT40-SMA40-60	2	40	60	80	-	28	38	6	12	5	M20	50	27	14	20	2.0
50	BT50-SMA16-75	1	16	75	38	-	-	17	-	8	3	M8	20	15	7	9	4.2
	BT50-SMA16-120	1	16	120	38	-	-	17	-	8	3	M8	20	15	7	9	5.8
	BT50-SMA22-75	1	22	75	42	-	-	27	-	8	3.5	M10	28	18	9	11	4.3
	BT50-SMA22-120	1	22	120	42	-	-	27	-	8	3.5	M10	28	18	9	11	4.8
	BT50-SMA22-180	1	22	180	42	-	-	27	-	8	3.5	M10	28	18	9	11	5.5
	BT50-SMA27-60	2	27	60	50	-	-	36	-	10	4	M12	33	23	10	12	4.3
	BT50-SMA27-105	2	27	105	50	60	-	36	-	10	4	M12	33	23	10	12	5.2
	BT50-SMA27-150	2	27	150	50	60	-	36	-	10	4	M12	33	23	10	12	5.8
	BT50-SMA32-45	2	32	45	60	-	24	38	6	10	4.5	M16	40	23	10	16	4.2
	BT50-SMA32-75	2	32	75	60	70	24	38	6	10	4.5	M16	40	23	10	16	5.2
	BT50-SMA32-105	2	32	105	60	70	24	38	6	10	4.5	M16	40	23	10	16	6.2
BT50-SMA40-45	2	40	45	80	-	28	38	6	12	5	M20	50	27	14	20	4.3	
BT50-SMA40-75	2	40	75	80	-	28	38	6	12	5	M20	50	27	14	20	5.5	

SPARE PARTS

TYPE	KEY		KEY BOLT		MOUNTING BOLT	
SMA 16		W8		M3 × 8		MB 8
SMA 22		W10		M4 × 10		MB10
SMA 27		W12		M5 × 12		MB12
SMA 32		W14		M6 × 16		MB16
SMA 40		W16		M6 × 16		MB20

SHELL MILL ARBOR AUFNAHMEDORN FÜR FRÄSER MIT BOHRUNG

DIN69893-HSK FORM A

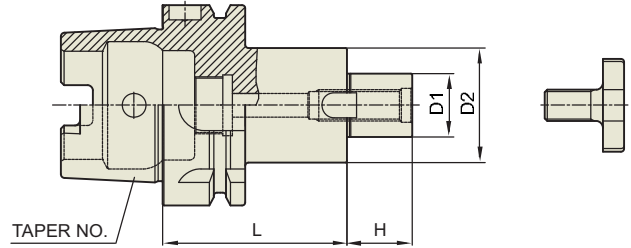

DIN69893 - HSK	Taper Accuracy AT3	G Value 6.3	RPM 12,000	Coolant System
-------------------	--------------------------	----------------	---------------	-------------------

TAPER No.	CODE No.	D1	D2	L	H	Weight (kg)
40A	HSK40A-SMA16-50	16	32	50	17	0.40
	HSK40A-SMA22-50	22	40	50	19	0.50
	HSK40A-SMA27-60	27	48	60	21	0.60
50A	HSK 50A-SMA16-50	16	38	50	17	0.50
	HSK 50A-SMA22-60	22	48	60	19	0.57
	HSK 50A-SMA27-60	27	58	60	21	0.75
	HSK 50A-SMA32-60	32	63	60	24	0.90
63A	HSK 63A-SMA16-50	16	38	50	17	0.81
	HSK 63A-SMA22-50	22	48	50	19	0.93
	HSK 63A-SMA27-60	27	58	60	21	1.22
	HSK 63A-SMA32-60	32	78	60	24	1.46
	HSK 63A-SMA40-60	40	88	60	27	1.80
100A	HSK100A-SMA16-50	16	38	50	17	2.14
	HSK100A-SMA22-50	22	48	50	19	2.25
	HSK100A-SMA27-50	27	58	50	21	2.40
	HSK100A-SMA32-50	32	78	50	24	2.60
	HSK100A-SMA40-60	40	88	60	27	3.25
	HSK100A-SMA50-70	50	129	70	30	5.40

SPARE PARTS

TYPE	KEY		KEY BOLT		MOUNTING BOLT	
SMA 16		W8		M3 × 8		MB 8
SMA 22		W10		M4 × 10		MB10
SMA 27		W12		M5 × 12		MB12
SMA 32		W14		M6 × 16		MB16
SMA 40		W16		M6 × 16		MB20

SHELL MILL ARBOR AUFNAHMEDORN FÜR FRÄSER MIT BOHRUNG

 TOOL
HOLDERS

DIN69871-SK

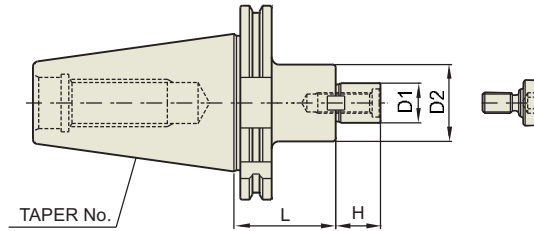
 DIN69871
-SK

 Taper
Accuracy
AT3

 G Value
6.3

 RPM
12,000

 Coolant
System

STANDARD

TAPER No.	CODE No.	D1	D2	L	H	Weight (kg)
30	SK30-SMA16-50	16	32	50	17	0.85
	SK30-SMA22-50	22	40	50	19	0.90
	SK30-SMA27-50	27	48	50	21	1.03
40	SK40-SMA16-60	16	32	60	17	0.35
	SK40-SMA22-60	22	40	60	19	1.45
	SK40-SMA27-60	27	48	60	21	1.70
	SK40-SMA32-60	32	58	60	24	1.80
50	SK40-SMA40-60	40	70	60	27	3.10
	SK50-SMA16-75	16	32	75	17	2.80
	SK50-SMA22-75	22	40	75	19	3.10
	SK50-SMA27-75	27	48	75	21	3.40
	SK50-SMA32-75	32	58	75	24	3.80
	SK50-SMA40-75	40	70	75	27	4.50
	SK50-SMA50-75	50	90	75	30	5.90

EXTENDED

TAPER No.	CODE No.	D1	D2	L	H	Weight (kg)
40	SK40-SMA16-120	16	32	120	17	1.70
	SK40-SMA22-120	22	40	120	19	1.80
	SK40-SMA27-120	27	48	120	21	2.40
	SK40-SMA32-120	32	58	120	24	3.70
50	SK50-SMA16-120	16	32	120	17	3.90
	SK50-SMA22-120	22	40	120	19	4.40
	SK50-SMA27-120	27	48	120	21	4.70
	SK50-SMA32-120	32	58	120	24	5.00
	SK50-SMA40-120	40	70	120	27	6.05

KEY FOR FACE MILL ARBOR

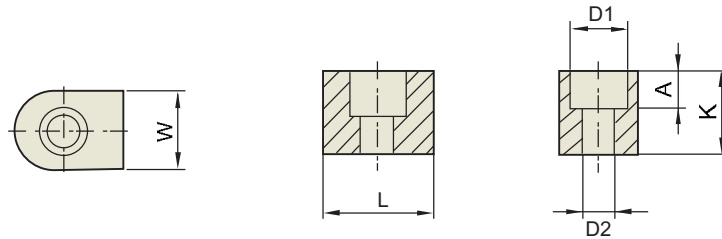

Size	W	K	L	D1	D2	A	Applicable arbor
8×7×12.8	8	7	12.8	5.8	3.2	3.2	SMA16
10×7.8×15.5	10	7.8	15.5	7.5	4.2	4.3	SMA22
9.52×9.52×10.2	9.52	9.52	10.2	7.5	4.5	5.2	FMA25.4 / FMB25.4
9.5×12×11	9.5	12	11	7.5	4.2	5	FMC25.4
12×9×18.5	12	9	18.5	9	5.3	5.5	SMA27
10×10×11	10	10	11	7.5	4.2	5	FMC22
14×11.5×20.5	14	11.5	20.5	10.5	6.5	6.5	SMA32
12×13×18	12	13	18	9	5.3	8	FMB27 / FMC27
16×13.5×23.5	16	13.5	23.5	10.5	6.5	6.5	SMA40
12.7×12.7×12.7	12.7	12.7	12.7	7.5	4.5	5.2	FMA31.75
15.87×15.87×18.5	15.87	15.87	18.5	10.3	6.6	7.5	FMA38.1 / FMB40 / FMB40F
14×15×20	14	15	20	10.5	6.3	8	FMC32
18×18×28.5	18	18	28.5	10.5	6.5	10	SMA50
19×18×22	19	18	22	10.5	6.3	7	FMA50.8

MOUNTING BOLT-MB

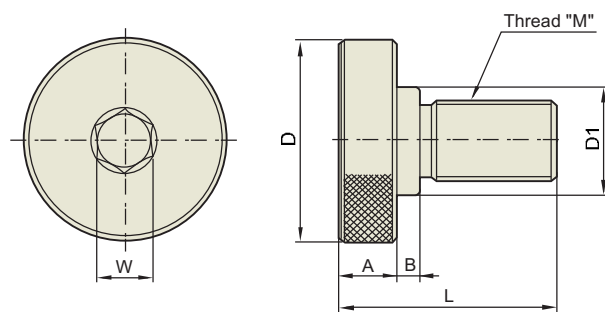

Size	M	D	D1	L	A	B	W	Applicable arbor
MB8	8X1.25	20	15	23	7	2	6	SMA16
MB10	10X1.5	28	18	29	9	2	8	SMA22
MB12	12×1.75	33	23	32	10	2	10	SMA27 / FMB27 / FMA25.4
MB16	16×2.0	40	23	42	10	6	12	SMA32 / FMA3.1.75
MB20	20×2.5	50	27	54	14	6	14	SMA40 / FMA38.1 / FMB40 / FMB40F
MB24	24×3.0	65	37	62	14	10	17	FMA50.8

**SIDE CUTTER ARBOR
SEITENSCHNEIDER LAUBE**

 TOOL
HOLDERS

MAS403-BT

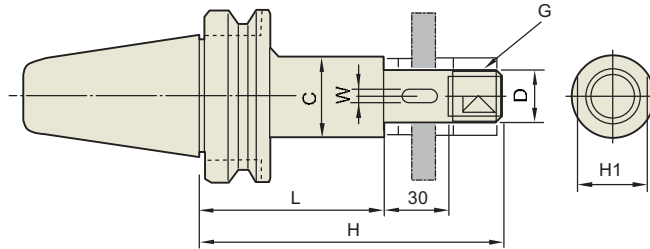

MAS403 -BT	Taper Accuracy AT3	G Value	RPM	Coolant System
---------------	--------------------------	---------	-----	-------------------

TAPER No.	CODE No.	H	H1	C	W	G	D	L	Weight (kg)
30	BT30-SCA12.7-60	105	17	20	—	M12	12.7	60	1.0
	BT30-SCA15.875-60	106	23	26	3.18	M14	15.875	60	1.1
	BT30-SCA22.225-60	110	29	34	3.18	M20	22.225	60	1.2
	BT30-SCA25.4-60	115	32	40	6.35	M24	25.4	60	1.3
40	BT40-SCA12.7-75	120	17	20	—	M12	12.7	75	1.2
	BT40-SCA12.7-105	150	17	20	—	M12	12.7	105	1.3
	BT40-SCA15.875-75	121	23	26	3.18	M14	15.875	75	1.4
	BT40-SCA15.875-120	151	23	26	3.18	M14	15.875	120	1.5
	BT40-SCA22.225-75	126	29	34	3.18	M20	22.225	75	1.7
	BT40-SCA22.225-120	171	29	34	3.18	M20	22.225	120	2.0
	BT40-SCA25.4-75	130	32	40	6.35	M24	25.4	75	2.0
	BT40-SCA25.4-120	175	32	40	6.35	M24	25.4	120	2.4
50	BT50-SCA31.75-90	150	41	46	7.92	M30	31.75	90	2.6
	BT50-SCA12.7-75	120	17	20	—	M12	12.7	75	4.1
	BT50-SCA12.7-105	150	17	20	—	M12	12.7	105	4.2
	BT50-SCA15.875-90	136	23	26	3.18	M14	15.875	90	4.2
	BT50-SCA15.875-120	166	23	26	3.18	M14	15.875	120	4.2
	BT50-SCA22.225-90	144	29	34	3.18	M20	22.225	90	4.4
	BT50-SCA22.225-135	186	29	34	3.18	M20	22.225	135	4.7
	BT50-SCA25.4-90	145	32	40	6.35	M24	25.4	90	4.5
	BT50-SCA25.4-135	190	32	40	6.35	M24	25.4	135	4.9
	BT50-SCA31.75-90	150	41	46	7.92	M30	31.75	90	4.7
BT50-SCA31.75-135	195	41	46	7.92	M30	31.75	135	5.2	
BT50-SCA38.1-90	156	46	55	9.52	M36	38.1	90	4.9	
BT50-SCA38.1-135	201	46	55	9.52	M36	38.1	135	5.9	

COMBI-SHELL MILL ARBOR KOMBI-AUFNAHMEDORN FÜR FRÄSER MIT BOHRUNG

DIN69893-HSK FORM A

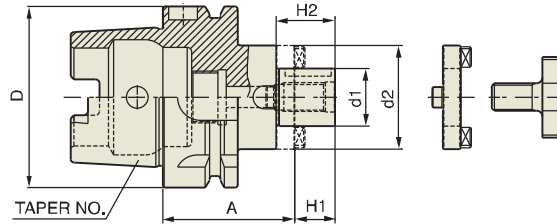

DIN69893 -HSK	Taper Accuracy AT3	G Value 6.3	RPM 12,000	Coolant System
------------------	--------------------------	----------------	---------------	-------------------

TAPER No.	CODE No.	D	d1	d2	A	H1	H2	PART No.	Weight (kg)
50A	HSK50A - CMA16 - 50	50	16	32	50	17	27	27,33,39	
	HSK50A - CMA22 - 50	50	22	40	50	19	31	28,34,40	
	HSK50A - CMA27 - 65	50	27	48	65	21	33	29,35,41	
	HSK50A - CMA32 - 65	50	32	58	65	24	38	30,36,42	
63A	HSK63A - CMA16 - 60	63	16	32	60	17	27	27,33,39	
	HSK63A - CMA22 - 60	63	22	40	60	19	31	28,34,40	
	HSK63A - CMA27 - 60	63	27	48	60	21	33	29,35,41	
	HSK63A - CMA32 - 60	63	32	58	60	24	38	30,36,42	
	HSK63A - CMA40 - 70	63	40	70	70	27	41	31,37,43	
100A	HSK100A - CMA16 - 60	100	16	32	60	17	27	27,33,39	
	HSK100A - CMA22 - 60	100	22	40	60	19	31	28,34,40	
	HSK100A - CMA27 - 60	100	27	48	60	21	33	29,35,41	
	HSK100A - CMA32 - 60	100	32	58	60	24	38	30,36,42	
	HSK100A - CMA40 - 70	100	40	70	70	27	41	31,37,43	
	HSK100A - CMA50 - 80	100	50	90	80	30	46	32,38,44	

- ▶ High Balanced combi-shell mill arbor are available on request
- ▶ Clutch drive ring, Collar bolt & key for CMA – part on page 1160

COMBI-SHELL MILL ARBOR

KOMBI-AUFNAHMEDORN FÜR FRÄSER MIT BOHRUNG

 TOOL
HOLDERS

DIN 69871-SK FORM A

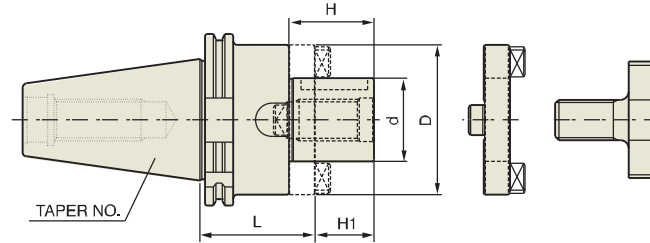
 DIN 69871
-SK

 Taper
Accuracy
AT3

 G Value
6.3

 RPM
12,000

 Coolant
System

STANDARD

TAPER No.	CODE No.	d	L	D	H1	H	PART No.	Weight (kg)
30	SK30 - CMA16 - 50	16	50	32	17	27	27,33,39	
	SK30 - CMA22 - 50	22	50	40	19	31	28,34,40	
	SK30 - CMA27 - 55	27	55	48	21	33	29,35,41	
40	SK40 - CMA16 - 55	16	55	32	17	27	27,33,39	
	SK40 - CMA22 - 55	22	55	40	19	31	28,34,40	
	SK40 - CMA27 - 55	27	55	48	21	33	29,35,41	
	SK40 - CMA32 - 60	32	60	58	24	38	30,36,42	
	SK40 - CMA40 - 60	40	60	70	27	41	31,37,43	
50	SK50 - CMA16 - 55	16	55	32	17	27	27,33,39	
	SK50 - CMA22 - 55	22	55	40	19	31	28,34,40	
	SK50 - CMA27 - 55	27	55	48	21	33	29,35,41	
	SK50 - CMA32 - 55	32	55	58	24	38	30,36,42	
	SK50 - CMA40 - 55	40	55	70	27	41	31,37,43	
	SK50 - CMA50 - 70	50	70	90	30	46	32,38,44	

EXTENDED

TAPER No.	CODE No.	d	L	D	H1	H	PART No.	Weight (kg)
40	SK40 - CMA16 - 100	16	100	32	17	27	27,33,39	
	SK40 - CMA22 - 100	22	100	40	19	31	28,34,40	
	SK40 - CMA27 - 100	27	100	48	21	33	29,35,41	
	SK40 - CMA32 - 100	32	100	58	24	38	30,36,42	
50	SK50 - CMA16 - 100	16	100	32	17	27	27,33,39	
	SK50 - CMA22 - 100	22	100	40	19	31	28,34,40	
	SK50 - CMA27 - 100	27	100	48	21	33	29,35,41	
	SK50 - CMA32 - 100	32	100	58	24	38	30,36,42	
	SK50 - CMA40 - 100	40	100	70	27	41	31,37,43	

- ▶ High Balanced combi-shell mill arbor are available on request
- ▶ Clutch drive ring, Collar bolt & key for CMA – part on page 1160

COMBI-SHELL MILL ARBOR
KOMBI-AUFNAHMEDORN FÜR FRÄSER MIT BOHRUNG

MAS403-BT

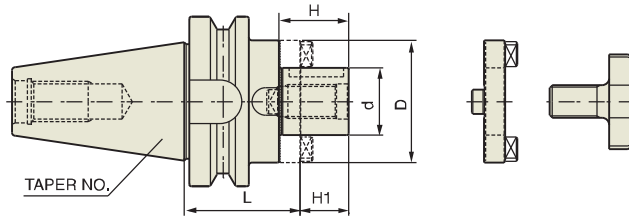

MAS403 -BT	Taper Accuracy AT3	G Value 6.3	RPM 12,000	Coolant System
---------------	--------------------------	----------------	---------------	-------------------

■ STANDARD

TAPER No.	CODE No.	d	L	D	H1	H	PART No.	Weight (kg)
30	BT30 - CMA16 - 50	16	50	32	17	27	27,33,39	
	BT30 - CMA22 - 50	22	50	40	19	31	28,34,40	
	BT30 - CMA27 - 55	27	55	48	21	33	29,35,41	
40	BT40 - CMA16 - 55	16	55	32	17	27	27,33,39	
	BT40 - CMA22 - 55	22	55	40	19	31	28,34,40	
	BT40 - CMA27 - 55	27	55	48	21	33	29,35,41	
	BT40 - CMA32 - 60	32	60	58	24	38	30,36,42	
	BT40 - CMA40 - 60	40	60	70	27	41	31,37,43	
50	BT50 - CMA16 - 70	16	70	32	17	27	27,33,39	
	BT50 - CMA22 - 70	22	70	40	19	31	28,34,40	
	BT50 - CMA27 - 70	27	70	48	21	33	29,35,41	
	BT50 - CMA32 - 70	32	70	58	24	38	30,36,42	
	BT50 - CMA40 - 70	40	70	70	27	41	31,37,43	
	BT50 - CMA50 - 70	50	70	90	30	46	32,38,44	

■ EXTENDED

TAPER No.	CODE No.	d	L	D	H1	H	PART No.	Weight (kg)
40	BT40 - CMA16 - 100	16	100	32	17	27	27,33,39	
	BT40 - CMA22 - 100	22	100	40	19	31	28,34,40	
	BT40 - CMA27 - 100	27	100	48	21	33	29,35,41	
	BT40 - CMA32 - 100	32	100	58	24	38	30,36,42	
50	BT50 - CMA16 - 100	16	100	32	17	27	27,33,39	
	BT50 - CMA22 - 100	22	100	40	19	31	28,34,40	
	BT50 - CMA27 - 100	27	100	48	21	33	29,35,41	
	BT50 - CMA32 - 100	32	100	58	24	38	30,36,42	
	BT50 - CMA40 - 100	40	100	70	27	41	31,37,43	

- ▶ High Balanced combi-shell mill arbor are available on request
- ▶ Clutch drive ring, Collar bolt & key for CMA – part on page 1160

COMBI-SHELL MILL ARBOR
KOMBI-AUFNAHMEDORN FÜR FRÄSER MIT BOHRUNG

 TOOL
HOLDERS

DIN2080-ISO

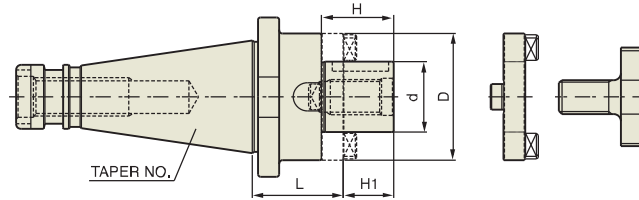
 DIN2080
- ISO

 Taper
Accuracy
AT3

 G Value
6.3

 RPM
12,000

 Coolant
System

STANDARD

TAPER No.	CODE No.	d	L	D	H1	H	PART No.	Weight (kg)
30	ISO30 - CMA16 - 35	16	35	32	17	27	27,33,39	
	ISO30 - CMA22 - 35	22	35	40	19	31	28,34,40	
	ISO30 - CMA27 - 35	27	35	48	21	33	29,35,41	
40	ISO40 - CMA16 - 52	16	52	32	17	27	27,33,39	
	ISO40 - CMA22 - 52	22	52	40	19	31	28,34,40	
	ISO40 - CMA27 - 52	27	52	48	21	33	29,35,41	
	ISO40 - CMA32 - 52	32	52	58	24	38	30,36,42	
50	ISO40 - CMA40 - 52	40	52	70	27	41	31,37,43	
	ISO50 - CMA16 - 55	16	55	32	17	27	27,33,39	
	ISO50 - CMA22 - 55	22	55	40	19	31	28,34,40	
	ISO50 - CMA27 - 55	27	55	48	21	33	29,35,41	
	ISO50 - CMA32 - 55	32	55	58	24	38	30,36,42	
	ISO50 - CMA40 - 55	40	55	70	27	41	31,37,43	
	ISO50 - CMA50 - 55	50	55	90	30	46	32,38,44	

EXTENDED

TAPER No.	CODE No.	d	L	D	H1	H	PART No.	Weight (kg)
40	ISO40 - CMA16 - 125	16	125	32	17	27	27,33,39	
	ISO40 - CMA22 - 125	22	125	40	19	31	28,34,40	
	ISO40 - CMA27 - 125	27	125	48	21	33	29,35,41	
	ISO40 - CMA32 - 125	32	125	58	24	38	30,36,42	
50	ISO50 - CMA16 - 125	16	125	32	17	27	27,33,39	
	ISO50 - CMA22 - 125	22	125	40	19	31	28,34,40	
	ISO50 - CMA27 - 125	27	125	48	21	33	29,35,41	
	ISO50 - CMA32 - 125	32	125	58	24	38	30,36,42	
	ISO50 - CMA40 - 125	40	125	70	27	41	31,37,43	

▶Clutch drive ring, Collar bolt & key for CMA – part on page 1160

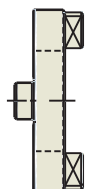
CMA - PART
CLUTCH DRIVE RING

N0.	CLUTCH DRIVE RING	Q' TY
27	#16	1
28	#22	1
29	#27	1
30	#32	1
31	#40	1
32	#50	1

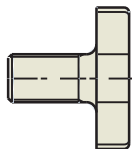
COLLAR BOLT

N0.	COLLAR BOLT	Q' TY
33	M8×1.25	1
34	M10×1.5	1
35	M12×1.75	1
36	M16×2.0	1
37	M20×2.5	1
38	M24×3.0	1

KEY



N0.	KEY	Q' TY	CMA DIA.
39	4×4×20	1	16
40	6×6×25	1	22
41	7×7×25	1	27
42	8×7×28	1	32
43	10×8×32	1	40
44	12×8×36	1	50



TWIN EDGE BORING BAR SET (Small Bore)
DOPPELSCHNEIDER - BOHRSTANGE

TOOL
HOLDERS

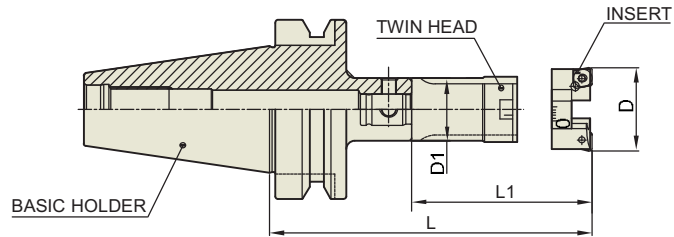
MAS403-BT



MAS403-BT	Taper Accuracy AT3	G Value	RPM	Coolant System
-----------	-----------------------	---------	-----	----------------

CODE No.	D	L	BASIC HOLDER	TWIN HEAD	D1	L1	INSERT
	Min - Max						
BT30-TBH25-90	Ø25 - Ø34	90	BT30-SAS22-40	SAS22-TBH25-50	22	50	CCMT060200
BT30-TBH25-140	Ø25 - Ø34	140	BT30-SAS22-90	SAS22-TBH25-50	22	50	CCMT060200
BT30-TBH34-110	Ø34 - Ø50	110	BT30-SAS31-50	SAS31-TBH34-60	31	60	CCMT060200
BT30-TBH34-150	Ø34 - Ø50	150	BT30-SAS31-90	SAS31-TBH34-60	31	60	CCMT060200
BT40-TBH25-100	Ø25 - Ø34	100	BT40-SAS22-50	SAS22-TBH25-50	22	50	CCMT060200
BT40-TBH25-140	Ø25 - Ø34	140	BT40-SAS22-90	SAS22-TBH25-50	22	50	CCMT060200
BT40-TBH25-155	Ø25 - Ø34	155	BT40-SAS22-105	SAS22-TBH25-50	22	50	CCMT060200
BT40-TBH34-120	Ø34 - Ø50	120	BT40-SAS31-60	SAS31-TBH34-60	31	60	CCMT060200
BT40-TBH34-160	Ø34 - Ø50	160	BT40-SAS31-100	SAS31-TBH34-60	31	60	CCMT060200
BT40-TBH34-180	Ø34 - Ø50	180	BT40-SAS31-120	SAS31-TBH34-60	31	60	CCMT060200
BT40-TBH50-140	Ø50 - Ø76	140	BT40-SAS42-60	SAS42-TBH50-80	42	80	CCMT09T300
BT40-TBH50-185	Ø50 - Ø76	185	BT40-SAS42-105	SAS42-TBH50-80	42	80	CCMT09T300
BT40-TBH50-200	Ø50 - Ø76	200	BT40-SAS42-120	SAS42-TBH50-80	42	80	CCMT09T300
BT40-TBH76-180	Ø76 - Ø116	180	BT40-SAS65-70	SAS65-TBH76-110	65	110	CCMT120400
BT40-TBH76-200	Ø76 - Ø116	200	BT40-SAS65-90	SAS65-TBH76-110	65	110	CCMT120400
BT40-TBH76-220	Ø76 - Ø116	220	BT40-SAS65-110	SAS65-TBH76-110	65	110	CCMT120400
BT40-TBH76-240	Ø76 - Ø116	240	BT40-SAS65-130	SAS65-TBH76-110	65	110	CCMT120400
BT50-TBH25-110	Ø25 - Ø34	110	BT50-SAS22-60	SAS22-TBH25-50	22	50	CCMT060200
BT50-TBH25-130	Ø25 - Ø34	130	BT50-SAS22-80	SAS22-TBH25-50	22	50	CCMT060200
BT50-TBH25-150	Ø25 - Ø34	150	BT50-SAS22-100	SAS22-TBH25-50	22	50	CCMT060200
BT50-TBH34-130	Ø34 - Ø50	130	BT50-SAS31-70	SAS31-TBH34-60	31	60	CCMT060200
BT50-TBH34-160	Ø34 - Ø50	160	BT50-SAS31-100	SAS31-TBH34-60	31	60	CCMT060200
BT50-TBH34-190	Ø34 - Ø50	190	BT50-SAS31-130	SAS31-TBH34-60	31	60	CCMT060200
BT50-TBH50-150	Ø50 - Ø76	150	BT50-SAS42-70	SAS42-TBH50-80	42	80	CCMT09T300
BT50-TBH50-190	Ø50 - Ø76	190	BT50-SAS42-110	SAS42-TBH50-80	42	80	CCMT09T300
BT50-TBH50-240	Ø50 - Ø76	240	BT50-SAS42-150	SAS42-TBH50-80	42	80	CCMT09T300
BT50-TBH76-200	Ø76 - Ø116	200	BT50-SAS65-90	SAS65-TBH76-110	65	110	CCMT120400
BT50-TBH76-240	Ø76 - Ø116	240	BT50-SAS65-130	SAS65-TBH76-110	65	110	CCMT120400
BT50-TBH76-280	Ø76 - Ø116	280	BT50-SAS65-170	SAS65-TBH76-110	65	110	CCMT120400
BT50-TBH116-225	Ø116 - Ø156	225	BT50-SAS84-80	SAS84-TBH116-145	84	145	CCMT120400
BT50-TBH116-275	Ø116 - Ø156	275	BT50-SAS84-130	SAS84-TBH116-145	84	145	CCMT120400
BT50-TBH116-325	Ø116 - Ø156	325	BT50-SAS84-180	SAS84-TBH116-145	84	145	CCMT120400

TWIN EDGE BORING BAR SET (Small Bore) DOPPELSCHNEIDER - BOHRSTANGE

DIN69871-SK

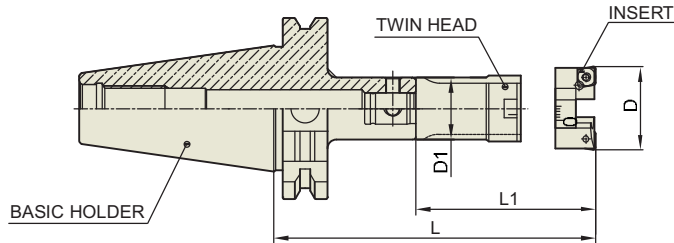

DIN69871 -SK	Taper Accuracy AT3	G Value	RPM	Coolant System
-----------------	--------------------------	---------	-----	-------------------

CODE No.	D		L	BASIC HOLDER	TWIN HEAD	D1	L1	INSERT
	Min	Max						
SK30-TBH25-90	Ø25	Ø34	90	SK30-SAS22-40	SAS22-TBH25-50	22	50	CCMT060200
SK30-TBH25-140	Ø25	Ø34	140	SK30-SAS22-90	SAS22-TBH25-50	22	50	CCMT060200
SK30-TBH34-110	Ø34	Ø50	110	SK30-SAS31-50	SAS31-TBH34-60	31	60	CCMT060200
SK30-TBH34-150	Ø34	Ø50	150	SK30-SAS31-90	SAS31-TBH34-60	31	60	CCMT060200
SK40-TBH25-100	Ø25	Ø34	100	SK40-SAS22-50	SAS22-TBH25-50	22	50	CCMT060200
SK40-TBH25-140	Ø25	Ø34	140	SK40-SAS22-90	SAS22-TBH25-50	22	50	CCMT060200
SK40-TBH25-155	Ø25	Ø34	155	SK40-SAS22-105	SAS22-TBH25-50	22	50	CCMT060200
SK40-TBH34-120	Ø34	Ø50	120	SK40-SAS31-60	SAS31-TBH34-60	31	60	CCMT060200
SK40-TBH34-160	Ø34	Ø50	160	SK40-SAS31-100	SAS31-TBH34-60	31	60	CCMT060200
SK40-TBH34-180	Ø34	Ø50	180	SK40-SAS31-120	SAS31-TBH34-60	31	60	CCMT060200
SK40-TBH50-140	Ø50	Ø76	140	SK40-SAS42-60	SAS42-TBH50-80	42	80	CCMT09T300
SK40-TBH50-185	Ø50	Ø76	185	SK40-SAS42-105	SAS42-TBH50-80	42	80	CCMT09T300
SK40-TBH50-200	Ø50	Ø76	200	SK40-SAS42-120	SAS42-TBH50-80	42	80	CCMT09T300
SK40-TBH76-180	Ø76	Ø116	180	SK40-SAS65-70	SAS65-TBH76-110	65	110	CCMT120400
SK40-TBH76-200	Ø76	Ø116	200	SK40-SAS65-90	SAS65-TBH76-110	65	110	CCMT120400
SK40-TBH76-220	Ø76	Ø116	220	SK40-SAS65-110	SAS65-TBH76-110	65	110	CCMT120400
SK40-TBH76-240	Ø76	Ø116	240	SK40-SAS65-130	SAS65-TBH76-110	65	110	CCMT120400
SK50-TBH25-110	Ø25	Ø34	110	SK50-SAS22-60	SAS22-TBH25-50	22	50	CCMT060200
SK50-TBH25-130	Ø25	Ø34	130	SK50-SAS22-80	SAS22-TBH25-50	22	50	CCMT060200
SK50-TBH25-150	Ø25	Ø34	150	SK50-SAS22-100	SAS22-TBH25-50	22	50	CCMT060200
SK50-TBH34-130	Ø34	Ø50	130	SK50-SAS31-70	SAS31-TBH34-60	31	60	CCMT060200
SK50-TBH34-160	Ø34	Ø50	160	SK50-SAS31-100	SAS31-TBH34-60	31	60	CCMT060200
SK50-TBH34-190	Ø34	Ø50	190	SK50-SAS31-130	SAS31-TBH34-60	31	60	CCMT060200
SK50-TBH50-150	Ø50	Ø76	150	SK50-SAS42-70	SAS42-TBH50-80	42	80	CCMT09T300
SK50-TBH50-190	Ø50	Ø76	190	SK50-SAS42-110	SAS42-TBH50-80	42	80	CCMT09T300
SK50-TBH50-240	Ø50	Ø76	240	SK50-SAS42-150	SAS42-TBH50-80	42	80	CCMT09T300
SK50-TBH76-200	Ø76	Ø116	200	SK50-SAS65-90	SAS65-TBH76-110	65	110	CCMT120400
SK50-TBH76-240	Ø76	Ø116	240	SK50-SAS65-130	SAS65-TBH76-110	65	110	CCMT120400
SK50-TBH76-280	Ø76	Ø116	280	SK50-SAS65-170	SAS65-TBH76-110	65	110	CCMT120400
SK50-TBH116-225	Ø116	Ø156	225	SK50-SAS84-80	SAS84-TBH116-145	84	145	CCMT120400
SK50-TBH116-275	Ø116	Ø156	275	SK50-SAS84-130	SAS84-TBH116-145	84	145	CCMT120400
SK50-TBH116-325	Ø116	Ø156	325	SK50-SAS84-180	SAS84-TBH116-145	84	145	CCMT120400



BASIC HOLDER

TOOL
HOLDERS

MAS403-BT

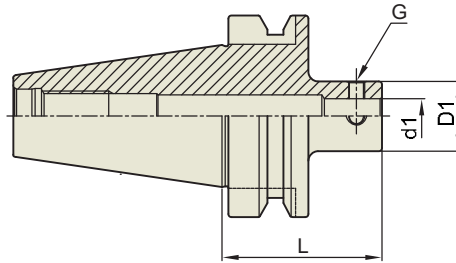

MAS403 -BT	Taper Accuracy AT3	G Value	RPM	Coolant System
---------------	--------------------------	---------	-----	-------------------

TAPER No.	CODE No.	d1	Dq	L	G	Weight (kg)
30	BT30-SAS22-40	Ø11	Ø22	40	M5	0.30
	BT30-SAS22-90	Ø11	Ø22	90	M5	0.40
	BT30-SAS31-50	Ø18	Ø31	50	M8	0.40
	BT30-SAS31-90	Ø18	Ø31	90	M8	0.50
40	BT40-SAS22-50	Ø11	Ø22	50	M5	1.70
	BT40-SAS22-90	Ø11	Ø22	90	M5	1.90
	BT40-SAS22-105	Ø11	Ø22	105	M5	1.90
	BT40-SAS31-60	Ø18	Ø31	60	M8	1.90
	BT40-SAS31-100	Ø18	Ø31	100	M8	2.30
	BT40-SAS31-120	Ø18	Ø31	120	M8	2.40
	BT40-SAS42-60	Ø24	Ø42	60	M10	2.70
	BT40-SAS42-105	Ø24	Ø42	105	M10	2.90
	BT40-SAS42-120	Ø24	Ø42	120	M10	3.10
	BT40-SAS65-70	Ø34	Ø65	70	M16	3.30
	BT40-SAS65-90	Ø34	Ø65	90	M16	3.60
	BT40-SAS65-110	Ø34	Ø65	110	M16	4.60
BT40-SAS65-130	Ø34	Ø65	130	M16	4.70	
50	BT50-SAS22-60	Ø11	Ø22	60	M5	4.30
	BT50-SAS22-80	Ø11	Ø22	80	M5	4.50
	BT50-SAS22-100	Ø11	Ø22	100	M5	4.70
	BT50-SAS31-70	Ø18	Ø31	70	M8	4.50
	BT50-SAS31-100	Ø18	Ø31	100	M8	5.10
	BT50-SAS31-130	Ø18	Ø31	130	M8	5.40
	BT50-SAS42-70	Ø24	Ø42	70	M10	5.00
	BT50-SAS42-110	Ø24	Ø42	110	M10	5.20
	BT50-SAS42-150	Ø24	Ø42	150	M10	5.50
	BT50-SAS65-90	Ø34	Ø65	90	M16	6.80
	BT50-SAS65-130	Ø34	Ø65	130	M16	7.50
	BT50-SAS65-170	Ø34	Ø65	170	M16	8.00
	BT50-SAS84-80	Ø46	Ø84	80	M16	9.00
	BT50-SAS84-130	Ø46	Ø84	130	M16	9.70
BT50-SAS84-180	Ø46	Ø84	180	M16	9.90	

BASIC HOLDER

DIN69871-SK

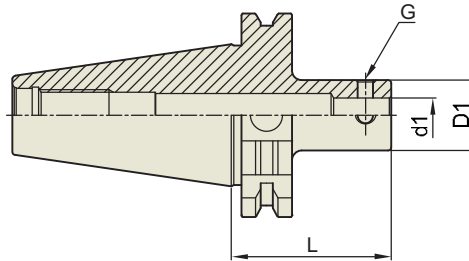
 DIN69871
-SK

 Taper
Accuracy

G Value

RPM

 Coolant
System

TAPER No.	CODE No.	d1	Dq	L	G	Weight (kg)
30	SK30-SAS22-40	Ø 11	Ø22	40	M5	0.30
	SK30-SAS22-90	Ø 11	Ø22	90	M5	0.40
	SK30-SAS31-50	Ø 18	Ø31	50	M8	0.40
	SK30-SAS31-90	Ø 18	Ø31	90	M8	0.50
40	SK40-SAS22-50	Ø 11	Ø22	50	M5	1.70
	SK40-SAS22-90	Ø 11	Ø22	90	M5	1.90
	SK40-SAS22-105	Ø 11	Ø22	105	M5	1.90
	SK40-SAS31-60	Ø 18	Ø31	60	M8	1.90
	SK40-SAS31-100	Ø 18	Ø31	100	M8	2.30
	SK40-SAS31-120	Ø 18	Ø31	120	M8	2.40
	SK40-SAS42-60	Ø24	Ø42	60	M10	2.70
	SK40-SAS42-105	Ø24	Ø42	105	M10	2.90
	SK40-SAS42-120	Ø24	Ø42	120	M10	3.10
	SK40-SAS65-70	Ø34	Ø65	70	M16	3.30
	SK40-SAS65-90	Ø34	Ø65	90	M16	3.60
	SK40-SAS65-110	Ø34	Ø65	110	M16	4.60
50	SK50-SAS65-130	Ø34	Ø65	130	M16	4.70
	SK50-SAS22-60	Ø 11	Ø22	60	M5	4.30
	SK50-SAS22-80	Ø 11	Ø22	80	M5	4.50
	SK50-SAS22-100	Ø 11	Ø22	100	M5	4.70
	SK50-SAS31-70	Ø 18	Ø31	70	M8	4.50
	SK50-SAS31-100	Ø 18	Ø31	100	M8	5.10
	SK50-SAS31-130	Ø 18	Ø31	130	M8	5.40
	SK50-SAS42-70	Ø24	Ø42	70	M10	5.00
	SK50-SAS42-110	Ø24	Ø42	110	M10	5.20
	SK50-SAS42-150	Ø24	Ø42	150	M10	5.50
	SK50-SAS65-90	Ø34	Ø65	90	M16	6.80
	SK50-SAS65-130	Ø34	Ø65	130	M16	7.50
	SK50-SAS65-170	Ø34	Ø65	170	M16	8.00
	SK50-SAS84-80	Ø46	Ø84	80	M16	9.00
SK50-SAS84-130	Ø46	Ø84	130	M16	9.70	
SK50-SAS84-180	Ø46	Ø84	180	M16	9.90	

TWIN HEAD

TOOL
HOLDERS

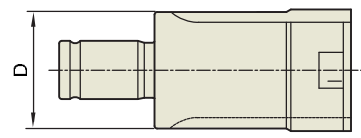

TWIN HEAD	D
SAS22-TBH25-50	22
SAS31-TBH34-60	31
SAS42-TBH50-80	42
SAS65-TBH76-110	65
SAS84-TBH116-145	84

INSERT HOLDER (CARTRIDGE)

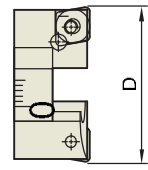

INSERT HOLDER	D	
	MIN	MAZ
TBH25-CC06	Ø25 - Ø34	
TBH34-CC06	Ø34 - Ø50	
TBH50-CC09	Ø50 - Ø76	
TBH76-CC12	Ø76 - Ø116	
TBH116-CC12	Ø116 - Ø156	

REDUCTION BAR

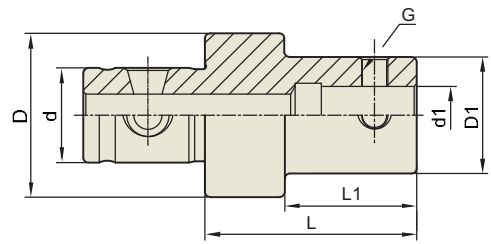

TWIN HEAD	d	d1	D	D1	L	L1	G
R-SAS31-22-40	Ø18	Ø11	Ø31	Ø22	40	25	M5
R-SAS42-22-45	Ø24	Ø11	Ø42	Ø22	45	25	M5
R-SAS42-31-50	Ø24	Ø18	Ø42	Ø31	50	30	M8
R-SAS65-22-50	Ø34	Ø11	Ø65	Ø22	50	25	M5
R-SAS65-31-55	Ø34	Ø18	Ø65	Ø31	55	30	M8
R-SAS65-42-65	Ø34	Ø24	Ø65	Ø42	65	40	M10
R-SAS84-22-55	Ø46	Ø11	Ø84	Ø22	55	25	M5
R-SAS84-31-60	Ø46	Ø18	Ø84	Ø31	60	30	M8
R-SAS84-42-65	Ø46	Ø24	Ø84	Ø42	65	40	M10
R-SAS84-65-70	Ø46	Ø34	Ø84	Ø65	70	40	M16

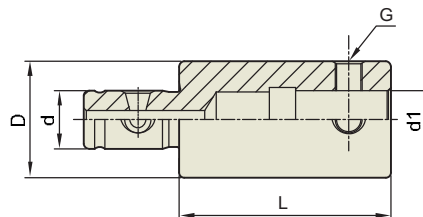
EXTENSION BAR

TWIN HEAD	d	d1	D	L	G
E-SAS22-40	Ø11	Ø11	Ø22	40	M5
E-SAS22-60	Ø11	Ø11	Ø22	60	M5
E-SAS31-50	Ø18	Ø18	Ø31	50	M8
E-SAS31-80	Ø18	Ø18	Ø31	80	M8
E-SAS42-60	Ø24	Ø24	Ø42	60	M10
E-SAS42-90	Ø24	Ø24	Ø42	90	M10
E-SAS65-70	Ø34	Ø34	Ø65	70	M16
E-SAS65-100	Ø34	Ø34	Ø65	100	M16
E-SAS84-90	Ø46	Ø46	Ø84	90	M16
E-SAS84-100	Ø46	Ø46	Ø84	100	M16

TWIN EDGE BORING BAR SET (Big Bore - For Rough Cutting) DOPPELSCHNEIDER - BOHRSTANGE

 TOOL
HOLDERS

MAS403-BT

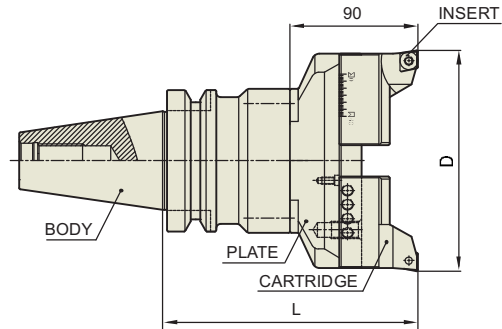
 MAS403
-BT

 Taper
Accuracy
AT3

G Value

RPM

 Coolant
System

CODE No.	D		L	BODY	PLATE	INSERT
	Min	Max				
BT50-TBH156-180	Ø156	Ø216	180	BT50-SAS102-90	PLA156	CCMT120400
BT50-TBH156-230	Ø156	Ø216	230	BT50-SAS102-140	PLA156	CCMT120400
BT50-TBH156-280	Ø156	Ø216	280	BT50-SAS102-190	PLA156	CCMT120400
BT50-TBH216-180	Ø216	Ø276	180	BT50-SAS102-90	PLA216	CCMT120400
BT50-TBH216-230	Ø216	Ø276	230	BT50-SAS102-140	PLA216	CCMT120400
BT50-TBH216-280	Ø216	Ø276	280	BT50-SAS102-190	PLA216	CCMT120400
BT50-TBH276-180	Ø276	Ø336	180	BT50-SAS102-90	PLA276	CCMT120400
BT50-TBH276-230	Ø276	Ø336	230	BT50-SAS102-140	PLA276	CCMT120400
BT50-TBH276-280	Ø276	Ø336	280	BT50-SAS102-190	PLA276	CCMT120400
BT50-TBH336-180	Ø336	Ø396	180	BT50-SAS102-90	PLA336	CCMT120400
BT50-TBH336-230	Ø336	Ø396	230	BT50-SAS102-140	PLA336	CCMT120400
BT50-TBH336-280	Ø336	Ø396	280	BT50-SAS102-190	PLA336	CCMT120400
BT50-TBH396-180	Ø396	Ø456	180	BT50-SAS102-90	PLA396	CCMT120400
BT50-TBH396-230	Ø396	Ø456	230	BT50-SAS102-140	PLA396	CCMT120400
BT50-TBH396-280	Ø396	Ø456	280	BT50-SAS102-190	PLA396	CCMT120400
BT50-TBH456-180	Ø456	Ø516	180	BT50-SAS102-90	PLA456	CCMT120400
BT50-TBH456-230	Ø456	Ø516	230	BT50-SAS102-140	PLA456	CCMT120400
BT50-TBH456-280	Ø456	Ø516	280	BT50-SAS102-190	PLA456	CCMT120400
BT50-TBH516-180	Ø516	Ø576	180	BT50-SAS102-90	PLA516	CCMT120400
BT50-TBH516-230	Ø516	Ø576	230	BT50-SAS102-140	PLA516	CCMT120400
BT50-TBH516-280	Ø516	Ø576	280	BT50-SAS102-190	PLA516	CCMT120400

TWIN EDGE BORING BAR SET (Big Bore - For Rough Cutting)
DOPPELSCHNEIDER - BOHRSTANGE

DIN69871-SK

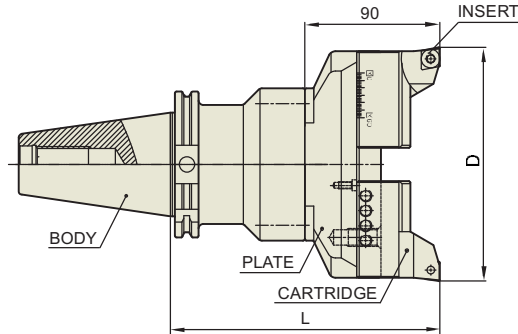

DIN69871
-SK

Taper
Accuracy
AT3

G Value

RPM

Coolant
System

CODE No.	D		L	BODY	PLATE	INSERT
	Min	Max				
SK50-TBH156-180	Ø156	Ø216	180	SK50-SAS102-90	PLA156	CCMT120400
SK50-TBH156-230	Ø156	Ø216	230	SK50-SAS102-140	PLA156	CCMT120400
SK50-TBH156-280	Ø156	Ø216	280	SK50-SAS102-190	PLA156	CCMT120400
SK50-TBH216-180	Ø216	Ø276	180	SK50-SAS102-90	PLA216	CCMT120400
SK50-TBH216-230	Ø216	Ø276	230	SK50-SAS102-140	PLA216	CCMT120400
SK50-TBH216-280	Ø216	Ø276	280	SK50-SAS102-190	PLA216	CCMT120400
SK50-TBH276-180	Ø276	Ø336	180	SK50-SAS102-90	PLA276	CCMT120400
SK50-TBH276-230	Ø276	Ø336	230	SK50-SAS102-140	PLA276	CCMT120400
SK50-TBH276-280	Ø276	Ø336	280	SK50-SAS102-190	PLA276	CCMT120400
SK50-TBH336-180	Ø336	Ø396	180	SK50-SAS102-90	PLA336	CCMT120400
SK50-TBH336-230	Ø336	Ø396	230	SK50-SAS102-140	PLA336	CCMT120400
SK50-TBH336-280	Ø336	Ø396	280	SK50-SAS102-190	PLA336	CCMT120400
SK50-TBH396-180	Ø396	Ø456	180	SK50-SAS102-90	PLA396	CCMT120400
SK50-TBH396-230	Ø396	Ø456	230	SK50-SAS102-140	PLA396	CCMT120400
SK50-TBH396-280	Ø396	Ø456	280	SK50-SAS102-190	PLA396	CCMT120400
SK50-TBH456-180	Ø456	Ø516	180	SK50-SAS102-90	PLA456	CCMT120400
SK50-TBH456-230	Ø456	Ø516	230	SK50-SAS102-140	PLA456	CCMT120400
SK50-TBH456-280	Ø456	Ø516	280	SK50-SAS102-190	PLA456	CCMT120400
SK50-TBH516-180	Ø516	Ø576	180	SK50-SAS102-90	PLA516	CCMT120400
SK50-TBH516-230	Ø516	Ø576	230	SK50-SAS102-140	PLA516	CCMT120400
SK50-TBH516-280	Ø516	Ø576	280	SK50-SAS102-190	PLA516	CCMT120400

TWIN EDGE BORING BAR (Big Bore - For Finishing) DOPPELSCHNEIDER - BOHRSTANGE

 TOOL
HOLDERS

MAS403-BT

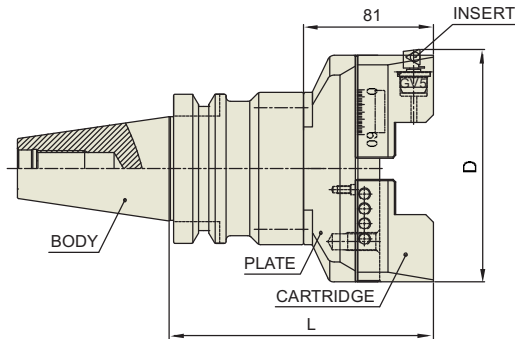
 MAS403
-BT

 Taper
Accuracy
AT3

G Value

RPM

 Coolant
System

CODE No.	D		L	BODY	PLATE	INSERT
	Min	Max				
BT50-FBH156-171	Ø156	Ø216	171	BT50-SAS102-90	PLA156	TPGT110400
BT50-FBH156-221	Ø156	Ø216	221	BT50-SAS102-140	PLA156	TPGT110400
BT50-FBH156-271	Ø156	Ø216	271	BT50-SAS102-190	PLA156	TPGT110400
BT50-FBH216-171	Ø216	Ø276	171	BT50-SAS102-90	PLA216	TPGT110400
BT50-FBH216-221	Ø216	Ø276	221	BT50-SAS102-140	PLA216	TPGT110400
BT50-FBH216-271	Ø216	Ø276	271	BT50-SAS102-190	PLA216	TPGT110400
BT50-FBH276-171	Ø276	Ø336	171	BT50-SAS102-90	PLA276	TPGT110400
BT50-FBH276-221	Ø276	Ø336	221	BT50-SAS102-140	PLA276	TPGT110400
BT50-FBH276-271	Ø276	Ø336	271	BT50-SAS102-190	PLA276	TPGT110400
BT50-FBH336-171	Ø336	Ø396	171	BT50-SAS102-90	PLA336	TPGT110400
BT50-FBH336-221	Ø336	Ø396	221	BT50-SAS102-140	PLA336	TPGT110400
BT50-FBH336-271	Ø336	Ø396	271	BT50-SAS102-190	PLA336	TPGT110400
BT50-FBH396-171	Ø396	Ø456	171	BT50-SAS102-90	PLA396	TPGT110400
BT50-FBH396-221	Ø396	Ø456	221	BT50-SAS102-140	PLA396	TPGT110400
BT50-FBH396-271	Ø396	Ø456	271	BT50-SAS102-190	PLA396	TPGT110400
BT50-FBH456-171	Ø456	Ø516	171	BT50-SAS102-90	PLA456	TPGT110400
BT50-FBH456-221	Ø456	Ø516	221	BT50-SAS102-140	PLA456	TPGT110400
BT50-FBH456-271	Ø456	Ø516	271	BT50-SAS102-190	PLA456	TPGT110400
BT50-FBH516-171	Ø516	Ø576	171	BT50-SAS102-90	PLA516	TPGT110400
BT50-FBH516-221	Ø516	Ø576	221	BT50-SAS102-140	PLA516	TPGT110400
BT50-FBH516-271	Ø516	Ø576	271	BT50-SAS102-190	PLA516	TPGT110400

TWIN EDGE BORING BAR (Big Bore - For Finishing)
DOPPELSCHNEIDER - BOHRSTANGE

DIN69871-SK

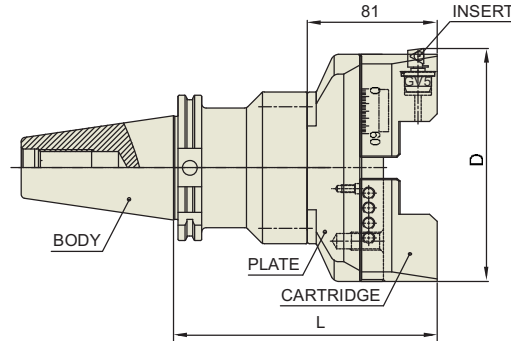

DIN69871 -SK	Taper Accuracy AT3	G Value	RPM	Coolant System
-----------------	--------------------------	---------	-----	-------------------

CODE No.	D		L	BODY	PLATE	INSERT
	Min	Max				
SK50-FBH156-171	Ø156	Ø216	171	SK50-SAS102-90	PLA156	TPGT110400
SK50-FBH156-221	Ø156	Ø216	221	SK50-SAS102-140	PLA156	TPGT110400
SK50-FBH156-271	Ø156	Ø216	271	SK50-SAS102-190	PLA156	TPGT110400
SK50-FBH216-171	Ø216	Ø276	171	SK50-SAS102-90	PLA216	TPGT110400
SK50-FBH216-221	Ø216	Ø276	221	SK50-SAS102-140	PLA216	TPGT110400
SK50-FBH216-271	Ø216	Ø276	271	SK50-SAS102-190	PLA216	TPGT110400
SK50-FBH276-171	Ø276	Ø336	171	SK50-SAS102-90	PLA276	TPGT110400
SK50-FBH276-221	Ø276	Ø336	221	SK50-SAS102-140	PLA276	TPGT110400
SK50-FBH276-271	Ø276	Ø336	271	SK50-SAS102-190	PLA276	TPGT110400
SK50-FBH336-171	Ø336	Ø396	171	SK50-SAS102-90	PLA336	TPGT110400
SK50-FBH336-221	Ø336	Ø396	221	SK50-SAS102-140	PLA336	TPGT110400
SK50-FBH336-271	Ø336	Ø396	271	SK50-SAS102-190	PLA336	TPGT110400
SK50-FBH396-171	Ø396	Ø456	171	SK50-SAS102-90	PLA396	TPGT110400
SK50-FBH396-221	Ø396	Ø456	221	SK50-SAS102-140	PLA396	TPGT110400
SK50-FBH396-271	Ø396	Ø456	271	SK50-SAS102-190	PLA396	TPGT110400
SK50-FBH456-171	Ø456	Ø516	171	SK50-SAS102-90	PLA456	TPGT110400
SK50-FBH456-221	Ø456	Ø516	221	SK50-SAS102-140	PLA456	TPGT110400
SK50-FBH456-271	Ø456	Ø516	271	SK50-SAS102-190	PLA456	TPGT110400
SK50-FBH516-171	Ø516	Ø576	171	SK50-SAS102-90	PLA516	TPGT110400
SK50-FBH516-221	Ø516	Ø576	221	SK50-SAS102-140	PLA516	TPGT110400
SK50-FBH516-271	Ø516	Ø576	271	SK50-SAS102-190	PLA516	TPGT110400



BASIC HOLDER (Big Bore)

TOOL
HOLDERS

MAS403-BT

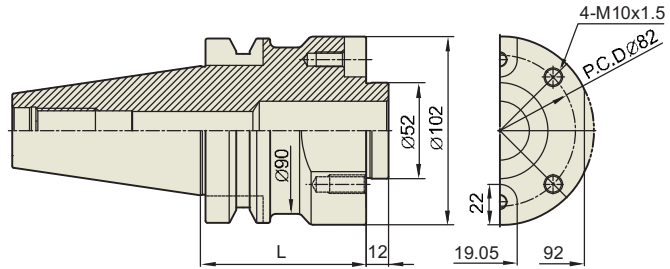

MAS403 -BT	Taper Accuracy AT3	G Value	RPM	Coolant System
---------------	--------------------------	---------	-----	-------------------

CODE No.	L
BT50-SAS102-90	90
BT50-SAS102-140	140
BT50-SAS102-190	190

DIN69871-SK

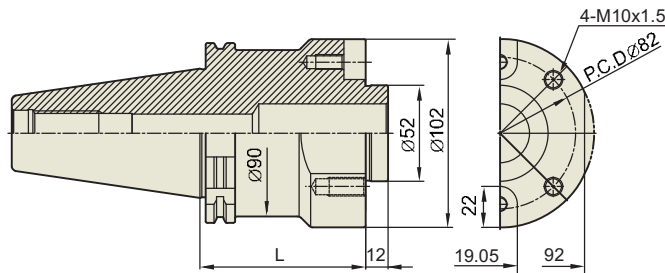

DIN69871 -SK	Taper Accuracy AT3	G Value	RPM	Coolant System
-----------------	--------------------------	---------	-----	-------------------

CODE No.	L
SK50-SAS102-90	90
SK50-SAS102-140	140
SK50-SAS102-190	190

PLATE

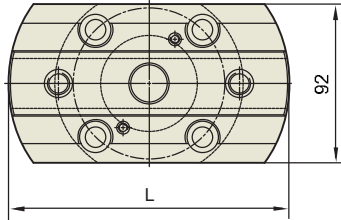

Taper Accuracy	G Value	RPM	Coolant System
AT3			

PLATE	L
PLA156	152
PLA216	212
PLA276	272
PLA336	332
PLA396	392
PLA456	452
PLA516	512

CARTRIDGE

FOR ROUGH CUTTING

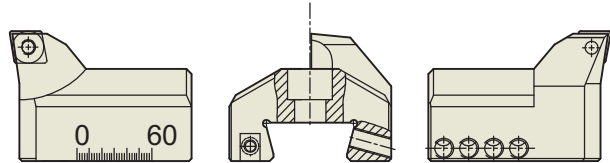

Taper Accuracy	G Value	RPM	Coolant System
AT3			

CARTRIDGE (For Rough Cutting)
CN120

FOR FINISHING

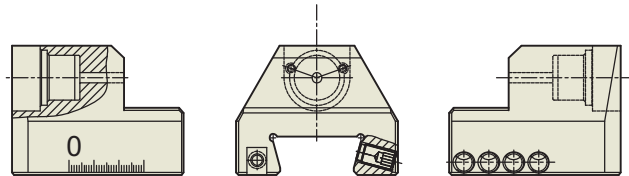

Taper Accuracy	G Value	RPM	Coolant System
AT3			

CARTRIDGE (For Finishing)
FBH-GV5

MICRO BORING BAR MIKRO - BOHRSTANGE

 TOOL
HOLDERS

MAS403-BT

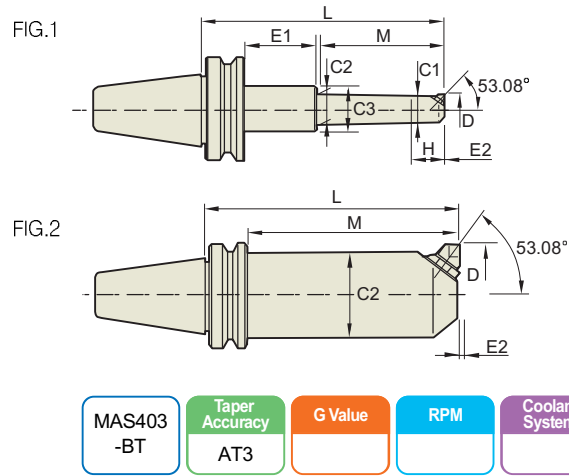

TAPER No.	CODE No.	FIG.	D		L	M	C1	C2	C3	H	E1	E2	UNIT	INSERT	Weight (kg)
			Min	Max											
30	BT30-BCA13.5-105	1	13.5	16	105	68	12	13.0	44	15	5	0.2	M1B2 E/F	BRAZED TYPE	
	BT30-BCA14.5-105	1	14.5	17	105	68	13	14.0	44	15	5	0.2	M1B2 E/F	BRAZED TYPE	
	BT30-BCA16-105	3	16	22.5	105	73	14	15	-	18	-	0.2	M1A2 E/F	BRAZED TYPE	
	BT30-BCA19-120	1	19	23	120	85	16	18	44	23	3	0.2	M2B 2XC	CCGTO401	0.70
	BT30-BCA23-135	3	23	29	135	105	19	22	-	24	-	0.2	M3B 2XT	TBGT0601	0.70
	BT30-BCA29-150	1	29	41	150	115	25	28	44	30	8	0.2	M3A 2XT	TBGT0601	0.90
	BT30-BCA29-195	1	29	41	195	115	25	28	44	30	53	0.2	M3A 2XT	TBGT0601	
	BT30-BCA38-210	1	38	49	150	115	33	35	55	41	8	0.2	M5B 2XT	TCMT1102	1.40
	BT30-BCA38-210	1	38	49	210	175	33	37	55	41	8	0.2	M5B 2XT	TCMT1102	
	BT30-BCA46-150	1	46	66	150	115	38	41	55	45	8	0.2	M5A 2XT	TCMT1102	2.10
	BT30-BCA46-210	1	46	66	210	175	38	45	55	45	8	0.2	M5A 2XT	TCMT1102	
BT30-BCA62-165	2	62	87	165	135	51	-	-	-	-	0.2	M7A 2XT	TCMT16T3		
40	BT40-BCA13.5-105	1	13.5	16	105	68	12	13.0	44	15	5	0.2	M1B2 E/F	BRAZED TYPE	
	BT40-BCA14.5-105	1	14.5	17	105	68	13	14.0	44	15	5	0.2	M1B2 E/F	BRAZED TYPE	
	BT40-BCA16-105	3	16	22.5	105	73	14	15	-	18	-	0.2	M1A2 E/F	BRAZED TYPE	
	BT40-BCA19-120	1	19	23	120	85	16	18	44	23	3	0.2	M2B2XC	CCGTO401	1.50
	BT40-BCA23-135	3	23	29	135	105	19	22	-	24	-	0.2	M3B2XT	TBGT0601	1.50
	BT40-BCA29-150	1	29	41	150	115	25	28	44	30	8	0.2	M3A2XT	TBGT0601	1.50
	BT40-BCA29-195	1	29	41	195	115	25	28	44	30	53	0.2	M3A2XT	TBGT0601	2.00
	BT40-BCA38-150	1	38	49	150	115	33	35	55	41	8	0.2	M5B2XT	TCMT1102	1.80
	BT40-BCA38-210	1	38	49	210	175	33	37	55	41	8	0.2	M5B2XT	TCMT1102	2.20
	BT40-BCA46-150	1	46	66	150	115	38	41	55	45	8	0.2	M5A2XT	TCMT1102	2.10
	BT40-BCA46-210	1	46	66	210	175	38	45	55	45	8	0.2	M5A2XT	TCMT1102	2.30
	BT40-BCA62-165	2	62	87	165	135	51	-	-	-	-	0.2	M7A2XT	TCMT16T3	2.90
	BT40-BCA62-210	2	62	87	210	180	51	-	-	-	-	0.2	M7A2XT	TCMT16T3	3.60
	BT40-BCA83-150	2	83	108	150	120	63	-	-	-	-	0.2	M7A2XT	TCMT16T3	
BT40-BCA83-210	2	83	108	210	180	63	-	-	-	-	0.2	M7A2XT	TCMT16T3		
BT40-BCA98-150	4	98	142	150	120	83	-	-	85	-	0.2	M10A2XT	TCMT16T3		

MICRO BORING BAR MIKRO - BOHRSTANGE

MAS403-BT

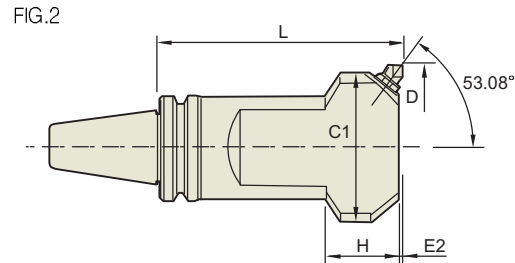
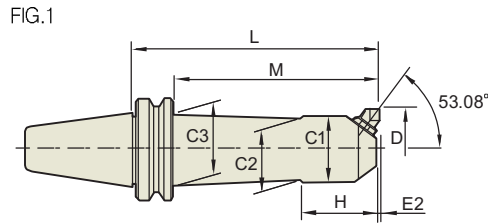

MAS403 -BT	Taper Accuracy AT3	G Value	RPM	Coolant System
---------------	--------------------------	---------	-----	-------------------

TAPER No.	CODE No.	FIG.	D		L	M	C1	C2	C3	H	E1	E2	UNIT	INSERT	Weight (kg)
			Min	Max											
50	BT50-BCA13.5-120	1	13.5	16	120	67	12	13	44	15	10	0.2	M1B2 E/F	—	
	BT50-BCA13.5-195	1	13.5	16	195	67	12	13	44	15	85	0.2	M1B2 E/F	—	
	BT50-BCA14.5-120	1	14.5	17	120	67	13	14	44	15	10	0.2	M1B2 E/F	—	
	BT50-BCA14.5-195	1	14.5	17	195	67	13	14	44	15	85	0.2	M1B2 E/F	—	
	BT50-BCA16-120	1	16	22.5	120	73	14	15	44	18	4	0.2	M1A2 E/F	—	
	BT50-BCA16-195	1	16	22.5	195	73	14	15	44	18	79	0.2	M1A2 E/F	—	
	BT50-BCA19-135	1	19	23	135	86	16	18	44	23	6	0.2	M2B2XC	CCGT0401	3.80
	BT50-BCA19-210	1	19	23	210	86	16	18	44	23	81	0.2	M2B2XC	CCGT0401	
	BT50-BCA23-150	1	23	29	150	105	19	22	44	24	2	0.2	M3B2XT	TBGT0601	3.90
	BT50-BCA23-225	1	23	29	225	105	19	22	44	24	77	0.2	M3B2XT	TBGT0601	
	BT50-BCA29-165	1	29	41	165	115	25	28	44	30	7	0.2	M3A2XT	TBGT0601	4.50
	BT50-BCA29-225	1	29	41	225	115	25	28	44	30	67	0.2	M3A2XT	TBGT0601	
	BT50-BCA38-165	1	38	49	165	115	33	35	55	41	7	0.2	M5B2XT	TCMT1102	
	BT50-BCA38-225	1	38	49	225	172	33	37	55	41	10	0.2	M5B2XT	TCMT1102	5.00
	BT50-BCA46-165	1	46	66	165	115	38	41	55	45	7	0.2	M5A2XT	TCMT1102	5.20
	BT50-BCA46-225	3	46	66	225	182	38	—	—	45	—	0.2	M5A2XT	TCMT1102	
	BT50-BCA46-255	1	46	66	255	206	38	—	55	45	6	0.2	M5A2XT	TCMT1102	5.70
	BT50-BCA62-180	2	62	87	180	137	51	—	—	—	—	0.2	M7A2XT	TCMT16T3	7.00
	BT50-BCA62-240	1	62	87	240	184	51	57	70	60	13	0.2	M7A2XT	TCMT16T3	7.60
	BT50-BCA62-330	1	62	87	330	280	51	60	70	60	7	0.2	M7A2XT	TCMT16T3	9.50
	BT50-BCA83-165	2	83	108	165	122	63	—	—	—	—	0.2	M7A2XT	TCMT16T3	
	BT50-BCA83-240	1	83	108	240	190	63	62	90	95	7	0.2	M7A2XT	TCMT16T3	
	BT50-BCA83-345	1	83	108	345	295	63	62	90	95	7	0.2	M7A2XT	TCMT16T3	
	BT50-BCA98-165	2	98	142	165	122	83	—	—	—	—	0.2	M10A2XT	TCMT16T3	
	BT50-BCA98-240	2	98	142	240	197	83	—	—	—	—	0.2	M10A2XT	TCMT16T3	
	BT50-BCA98-345	3	98	142	345	302	83	92	—	85	—	0.2	M10A2XT	TCMT16T3	
	BT50-BCA132-210	4	132	176	210	—	108	—	—	65	—	0.2	M10A2XT	TCMT16T3	
	BT50-BCA132-315	4	132	176	315	—	108	—	—	65	—	0.2	M10A2XT	TCMT16T3	
	BT50-BCA166-225	4	166	210	225	—	142	—	—	70	—	0.2	M10A2XT	TCMT16T3	
	BT50-BCA166-315	4	166	210	315	—	142	—	—	70	—	0.2	M10A2XT	TCMT16T3	
BT50-BCA200-210	4	200	244	210	—	176	—	—	75	—	0.2	M10A2XT	TCMT16T3		

**MICRO BORING BAR
MIKRO - BOHRSTANGE**

 TOOL
HOLDERS

ST

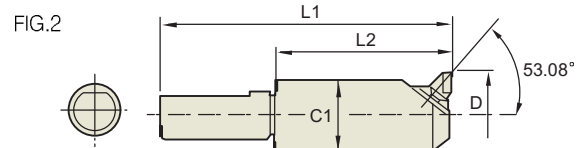
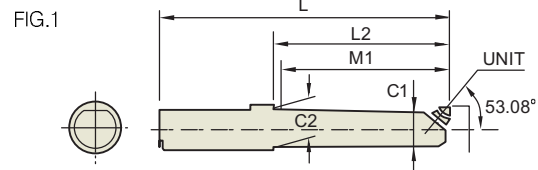

K	Taper Accuracy AT3	G Value	RPM	Coolant System
---	-----------------------	---------	-----	----------------

STYLE	CODE No.	FIG.	D		L1	L2	M1	C1	C2	MICRO UNIT	Weight (kg)
			Min	Max							
32	ST32-BCA13.5-75	1	13.5	16	135	75	67	12	13	M1B2E/F	0.5
	ST32-BCA14.5-75	1	14.5	17	145	75	67	12	14	M1B2E/F	0.5
	ST32-BCA16-90	1	16	22.5	160	90	82	14	15	M1A2E/F	0.5
	ST32-BCA19-90	1	19	23.0	160	90	82	16	18	M2B-2XC	0.5
	ST32-BCA23-120	1	23	29.0	190	120	110	19	22	M3B-2XT	1
	ST32-BCA29-120	1	29	41.0	190	120	110	25	28	M3A-2XT	1
	ST32-BCA38-120	2	38	49.0	190	120	115	33	35	M5B-2XT	1.5
	ST32-BCA46-120	2	46	66	190	120	115	38	-	M5A-2XT	1.5
42	ST32-BCA62-120	2	62	87.0	190	120	115	51	-	M7A-2XT	2.5
	ST42-BCA13.5-85	1	13.5	16	165	85	67	12	13	M1B2E or F	1.0
	ST42-BCA14.5-85	1	14.5	17	165	85	67	12	14	M1B2E or F	1.0
	ST42-BCA16-100	1	16	22.5	180	100	82	14	15	M1A2E or F	1.0
	ST42-BCA19-100	1	19	23.0	180	100	82	16	18	M2B2E or F	1.0
	ST42-BCA23-120	1	23	29.0	200	120	110	19	22	M3B-2XT	1.5
	ST42-BCA29-120	1	29	41.0	200	120	110	25	28	M3A-2XT	1.5
	ST42-BCA38-130	1	38	49.0	210	130	125	33	35	M5B-2XT	1.5
	ST42-BCA46-135	1	46	66.0	215	135	130	38	44	M5A-2XT	1.5
	ST42-BCA62-135	2	62	87.0	215	135	130	51	-	M7A-2XT	2.5
ST42-BCA83-150	2	83	108	230	150	145	63	-	M7A-2XT	3.0	

LARGE SIZE MICRO CUT BORING BAR(BRA)

MAS403-BT

■ BORING RING HOLDER

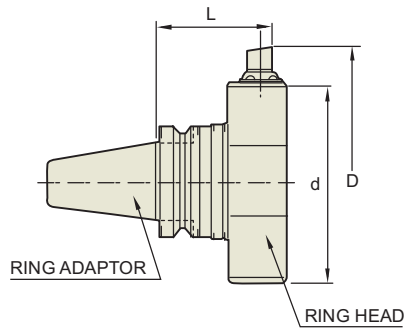

CODE NO.	d	D	L
BT50-BRA140-105	140	197	105
BT50-BRA140-165	140	197	165
BT50-BRA191-105	191	248	105
BT50-BRA191-165	191	248	165
BT50-BRA242-105	242	299	105
BT50-BRA242-165	242	299	165
BT50-BRA293-105	293	350	105
BT50-BRA293-165	293	350	165
BT50-BRA344-105	344	401	105
BT50-BRA344-165	344	401	165
BT50-BRA395-105	395	452	105
BT50-BRA395-165	395	452	165

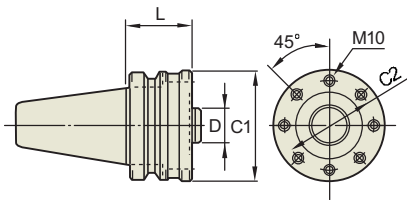

■ RING ADAPTER

CODE NO.	D(h6)	L	C1	C2
BT50-RAA32-60	32	60	102	82
BT50-RAA32-120	32	120	102	82

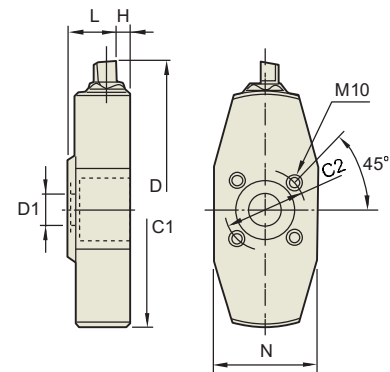

■ RING HEAD

CODE No.	D1(H7)	D		L	C1	C2	H	N	MICRO UNIT
		Min	Max						
RH32-BCA140	32	140	197	45	102	82	14	-	M10A2XT
RH32-BCA191	32	191	248	45	136	82	14	-	M10A2XT
RH32-BCA242	32	242	299	45	184	82	14	103	M10A2XT
RH32-BCA293	32	293	350	45	234	82	14	103	M10A2XT
RH32-BCA344	32	344	401	45	284	82	14	103	M10A2XT
RH32-BCA395	32	395	452	45	36	82	14	103	M10A2XT



**STRENGTH OF BORING BAR AND COMPARISON TABLE
OF MICRO UNITS**

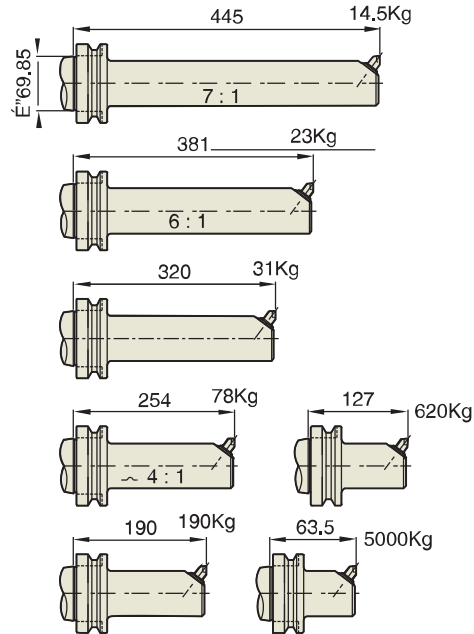
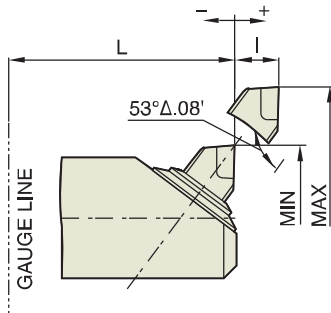

BORING BAR CODE NO.	BRAZED TYPE B EF		SCREW ON TYPE			Insert Spec
	MIN	MAX	MIN	MAX	∇L	
BCA 19	M2B2	M2B2				CCGT0401
	19	23			-1.9	CCGT0401
BCA 23	M3B2	M3B2	M3B2XT	M3B2XT	M3B2XT	TBGT 060102
	23	29	24.9	30.9	-1.9	TBGT 060102
BCA 29	M3A2	M3A2	M3A2XT	M3A2XT	M3A2XT	TBGT 060102
	29	41.8	30.9	43.8	-1.9	TBGT 060102
BCA 38	M5B2	M5B2	M5B2XT	M5B2XT	M5B2XT	TCMT 110204
	38	49.2	40.9	52.1	-1.9	TCMT 110204
BCA 46	M5A2	M5A2	M5A2XT	M5A2XT	M5A2XT	TCMT 110204
	46	66.6	48.9	69.5	-1.9	TCMT 110204
BCA 62	M7A2	M7A2	M7A2XT	M7A2XT	M7A2XT	TCMT 16T304
	62	87.4	62	87.4	0	TCMT 16T304
BCA 83	M7A2	M7A2	M7A2XT	M7A2XT	M7A2XT	TCMT 16T304
	83	108.4	83	108.4	0	TCMT 16T304
BCA 98	M10A2	M10A2	M10A2XT	M10A2XT	M10A2XT	TCMT 16T304
	98	142.4	98	142.4	0	TCMT 16T304
BCA 132	M10A2	M10A2	M10A2XT	M10A2XT	M10A2XT	TCMT 16T304
	132	176.4	132	176.4	0	TCMT 16T304
BCA 166	M10A2	M10A2	M10A2XT	M10A2XT	M10A2XT	TCMT 16T304
	166	210.4	166	210.4	0	TCMT 16T304
BCA 200	M10A2	M10A2	M10A2XT	M10A2XT	M10A2XT	TCMT 16T304
	200	244.4	200	244.4	0	TCMT 16T304

MICRO UNIT SPARE PART

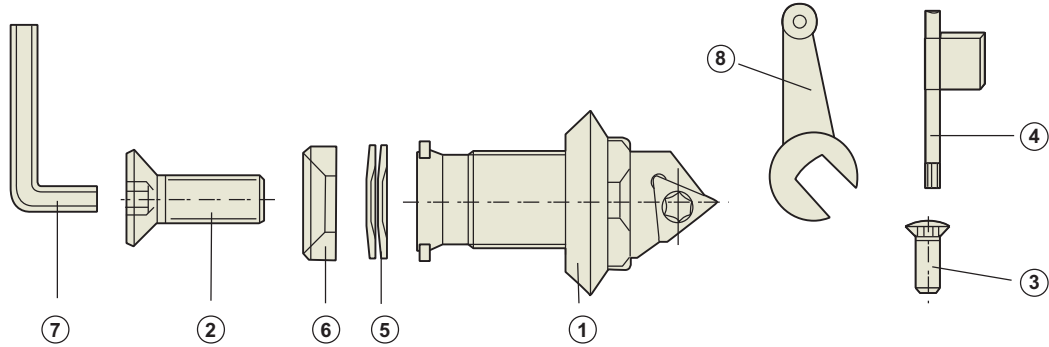

ORDER NO.		M1A-B	M2A-B	M3A-B	M5A-B	M5A-B	M7A-B	M10A-B	
PART NAME									
1	DIAL NUT	Slant Angle	1-40	2-40	3-40	5-40	5-40	7-80	10-80
		Right Angle	1-50	2-50	3-50	5-50	5-50	7-100	10-100
2	CARTRIDGE BOLT	M-A	F-M3-0.5-8	F-M3-0.5-12	F-M4-0.7-15	F-M6-1.0-25	F-M6-1.0-25	F-M10-1.5-30	M12-1,75-50
		M-B	M-M3-0.5-6	M-M3-0.5-10	M-M4-0.7-12	M-M6-1.0-20	M-M6-1.0-20	M-M10-1.5-25	M12-1,75-35
3	INSERT SCREW	S1845L5	S1845L5	S2045L6	S2555L6	S2555L6	S4095L6	S4095L6	
4	T-WRENCH	T6	T6	T6	T8	T8	T15	T15	
5	SPRING WASHER		CB-2	CB-3	CB-5	CB-5	CB-7	CB-10	
6	MOUNTING WASHER		2306	3306	5306	5306	7306	10306	
7	L-WRENCH	WR-2	WR-2	WR-2.5	WR-4	WR-4	WR-6	WR-8	
8	SPANNER	GS12	GS12	GS35	GS35	GS35	GS710	GS710	

GRADUATED DIAL UNIT

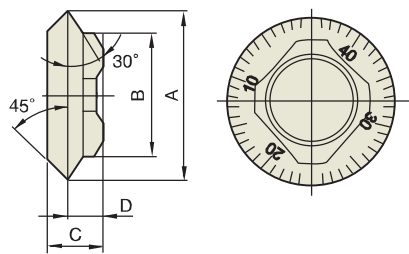

SIZE	A	B	C	D
M1	9.53	6.99	4.45	2.54
M2	12.7	9.53	5.08	3.30
M3	15.88	11.3	5.59	3.56
M5	25.4	19.05	8.76	4.83
M7	34.93	25.40	11.68	7.11
M10	44.45	34.93	13.84	7.49

LOCK SCREW AND WASHER

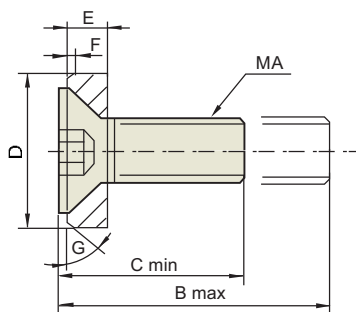

SIZE	A	B	C	D	E	F	G
M1	M3	8	6	-	-	-	-
M2	M3	12	10	7.82	1.83	0.5	45°
M3	M4	15	12	10.9	2.46	1.0	45°
M5	M6	25	20	15.7	4.32	0.8	37°
M7	M10	30	25	23.7	6.35	1.30	37°
M10	M12	50	35	31.6	7.92	2.5	37°



SQUARE BORING BAR (45°)
VIERKANT - BOHRSTANGE (45°)

TOOL
HOLDERS

MAS403-BT

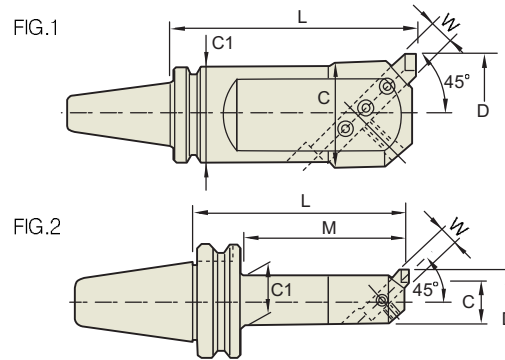

MAS403 -BT	Taper Accuracy AT3	G Value	RPM	Coolant System
---------------	--------------------------	---------	-----	-------------------

TAPER No.	CODE No.	D		L	C	C1	W	M	Weight (kg)
		Min	Max						
30	BT30-BSA25-120	25	38	120	20	22	8	90	1.0
	BT30-BSA30-135	30	42	135	24	26	8	105	1.1
	BT30-BSA38-150	38	52	150	30	33	10	120	1.4
	BT30-BSA42-150	42	56	150	34	37	10	125	1.6
	BT30-BSA50-150	50	65	150	40	44	13	125	1.8
40	BT40-BSA25-135	25	38	135	20	22	8	108	1.3
	BT40-BSA30-165	30	42	165	24	26	8	138	1.5
	BT40-BSA38-180	38	52	180	30	33	10	153	1.8
	BT40-BSA42-210	42	56	210	34	37	10	183	2.3
	BT40-BSA50-180	50	65	180	40	44	13	153	2.4
	BT40-BSA50-225	50	65	225	40	44	13	198	2.9
	BT40-BSA62-180	62	90	180	50	54	16	153	3.2
	BT40-BSA62-240	62	90	240	50	54	16	213	4.2
	BT40-BSA72-180	72	110	180	60	63	19	153	4.4
	BT40-BSA72-240	72	110	240	60	63	19	213	5.7
50	BT40-BSA90-180	90	125	180	75	63	19	153	5.4
	BT50-BSA25-135	25	38	135	20	22	8	95	4.4
	BT50-BSA30-165	30	42	165	24	26	8	125	4.6
	BT50-BSA38-180	38	52	180	30	33	10	140	4.8
	BT50-BSA42-210	42	56	210	34	37	10	170	5.0
	BT50-BSA50-180	50	65	180	40	44	13	140	5.4
	BT50-BSA50-240	50	65	240	40	44	13	200	5.7
	BT50-BSA62-195	62	90	195	50	54	16	155	6.1
	BT50-BSA62-270	62	90	270	50	54	16	230	7.5
	BT50-BSA72-195	72	110	195	60	66	19	155	6.9
	BT50-BSA72-285	72	110	285	60	66	19	245	9.3
	BT50-BSA90-210	90	125	210	75	80	19	170	9.2
	BT50-BSA90-300	90	125	300	75	80	19	260	12.3
BT50-BSA105-195	105	160	195	90	90	25	157	10.5	
BT50-BSA105-285	105	160	285	90	90	25	247	14.8	

SQUARE BORING BAR (90°)
VIERKANT - BOHRSTANGE (90°)

MAS403-BT

FIG.1

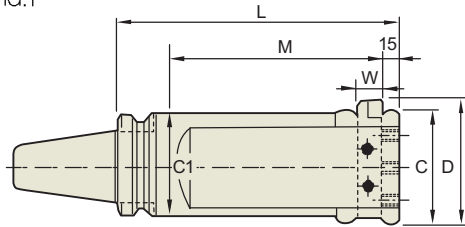
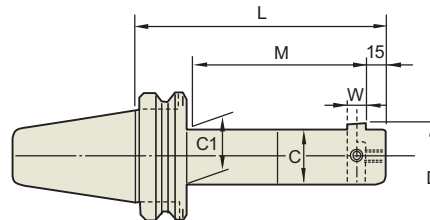

FIG.2



MAS403 -BT	Taper Accuracy AT3	G Value	RPM	Coolant System
---------------	--------------------------	---------	-----	-------------------

TAPER No.	CODE No.	D		L	C	C1	W	M	Weight (kg)
		Min	Max						
30	BT30-BSB25-120	25	50	120	20	22	8	90	1.1
	BT30-BSB38-150	38	70	150	30	33	10	120	1.5
	BT30-BSB50-150	50	90	150	40	44	13	125	2.2
40	BT40-BSB25-135	25	50	135	20	22	8	108	1.3
	BT40-BSB38-180	38	70	180	30	33	10	153	1.9
	BT40-BSB50-180	50	90	180	40	44	13	153	2.6
	BT40-BSB50-225	50	90	225	40	44	13	198	3.1
	BT40-BSB62-180	62	115	180	50	56	16	153	3.4
	BT40-BSB62-225	62	115	225	50	56	16	198	4.1
	BT40-BSB72-180	72	135	180	60	66	19	153	4.7
	BT40-BSB72-225	72	135	225	60	66	19	198	5.6
	BT40-BSB90-180	90	150	180	75	80	19	153	5.7
	BT40-BSB90-225	90	150	225	75	80	19	198	6.6
50	BT50-BSB25-135	25	50	135	20	22	8	95	4.1
	BT50-BSB38-180	38	70	180	30	33	10	140	4.8
	BT50-BSB50-180	50	90	180	40	44	13	140	5.5
	BT50-BSB50-240	50	50	240	40	44	13	200	5.7
	BT50-BSB62-195	62	115	195	50	56	16	155	6.4
	BT50-BSB62-270	62	115	270	50	56	16	230	7.9
	BT50-BSB72-195	72	135	195	60	66	19	155	7.3
	BT50-BSB72-285	72	135	285	60	66	19	245	9.6
	BT50-BSB90-210	90	150	210	75	80	19	170	9.6
	BT50-BSB90-300	90	150	300	75	80	19	260	12.6
	BT50-BSB105-195	105	190	195	90	-	25	155	11.1
	BT50-BSB105-285	105	190	285	90	94	25	245	15.4



SQUARE BITE

TOOL
HOLDERS

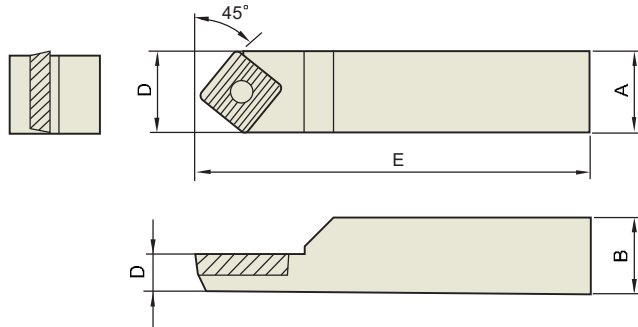

classification Size	A	B	C	D	E	SCREW	WRENCH	INSERT
SBC08-45	08	08	6.3	8.39	70	SSB-2506	T7	CCMT0602
SBC10-45	10	10	7	10.39	70	SSB-2506	T7	CCMT0602
SBC13-45	13	13	10	13.6	80	SSB-4009	T15	CCMT09T3
SBC16-45	16	16	11	16.68	100	SSB-5012	T15	CCMT1204
SBC19-45	19	19	11	19.68	100	SSB-5012	T15	CCMT1204
SBC25-45	25	25	12.5	25.68	120	SSB-5012	T15	CCMT1204

SQUARE BITE

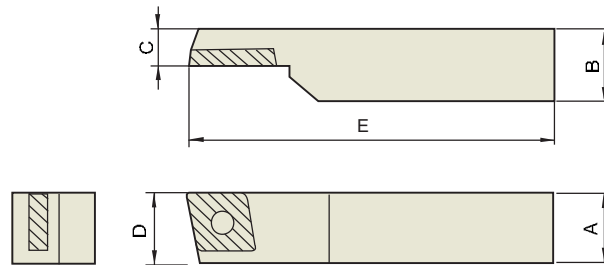

classification Size	A	B	C	D	E	SCREW	WRENCH	INSERT
SBC08-90	08	08	6.3	8.4	70	SSB-2506	T7	CCMT0602
SBC10-90	10	10	7	10.4	70	SSB-2506	T7	CCMT0602
SBC13-90	13	13	10	13.6	80	SSB-4009	T15	CCMT09T3
SBC16-90	16	16	11	16.7	100	SSB-5012	T15	CCMT1204
SBC19-90	19	19	11	19.7	100	SSB-5012	T15	CCMT1204
SBC25-90	25	25	12.5	25.7	120	SSB-5012	T15	CCMT1204

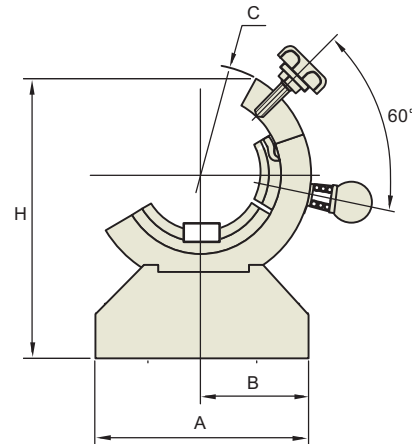
**TOOL CLAMPER
MONTAGEVORRICHTUNGEN**

Flange Clamping	Taper Clamping
YES	NO

TAPER No.	CODE No.	A	B	C	H	Weight (kg)
BT30	TCP30	125	65	108	135	3.0
BT40	TCP40	160	80	138	180	7.6
BT50	TCP50	180	90	165	205	8.6
SK30	TSK30	125	65	108	135	3.0
SK40	TSK40	160	80	138	180	7.6
SK50	TSK50	180	90	165	205	8.6

FEATURES

1. No surface damage such as abrasion and scratch around taper shank closely associated with tool runout
2. Easy to assemble and disassemble pull stud bolt
3. Convenient and safe when using spanner wrench with milling chuck or ER collet chuck

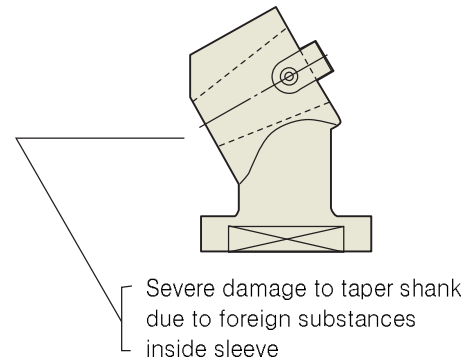

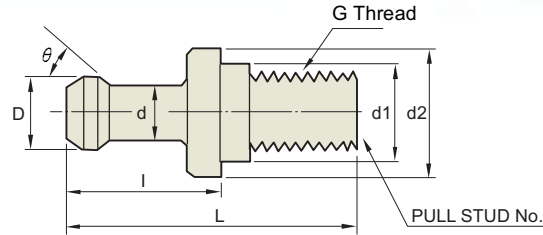
**PULL STUD BOLT
ANZUGBOLZEN**

CODE No.	D	d2	d1	d	L	l	G	θ	TYPE
PS-1	15	23	17	10	60	35	M16	45°	BT40- I standard type
PS-2	15	23	17	10	60	35	M16	60°	BT40- II standard type
PS-5	23	38	25	17	85	45	M24	45°	BT50- I standard type
PS-6	23	38	25	17	85	45	M24	60°	BT50- II standard type
PS-16	11	16.5	12.5	7	43	23	M12	45°	BT30- I standard type
PS-17	11	16.5	12.5	7	43	23	M12	60°	BT30- II standard type
PS-0	23	38	25	17	85	45	M24	90°	For BT50 OKK
PS-08	15	23	17	10	60	35	M16	90°	For BT40 OKK
PS-P	24	36	25	18	71	31	M24	90°	For BT50 MITISUI SEIKI
PS-P5	15	23	17	10	50	25	M16	90°	For BT40 MITISUI SEIKI
PS-G41	29	37	25	21	65.2	25.2	M24	45°	For BT50 MASAK
PS-G51	18.8	22	17	12	44.1	19.1	M16	45°	For BT40 MASAK
PS-S2	25	39	25	18	95	55	M24	60°	For SHIN NIPPON KOKI
PS-F1	23	39	25	18	104	64	M24	45°	For MITSUBISHI
PS-B1	22	38	25	16	112	72	M24	60°	For OKUMA
PSS-1	19	23	17	14	54	26	M16	75°	For SK40
PSS-5	28	36	25	21	74	34	M24	75°	For SK50

▶ Other special sizes of hydraulic chucks will be manufactured.

▶ Through hole type ("H" type) is available upon request .

COMPARISON TABLE OF PULL STUD

MACHINE MANUFACTURER	PS / BOLT	PS / BOLT	PS / BOLT	MACHINE MANUFACTURER	PS / BOLT	PS / BOLT	PS / BOLT
DOOSAN	ACE-TC400	BT30	PS-16	DOOSAN	NR 510M	BT50	PS-5
	ACE-TC320D	BT30	PS-16		NR 700	BT50	PS-5
	Mynx NM410	BT40	PS-1		VM560/50	BT50	PS-5
	Mynx 410	BT40	PS-5		VM 70(H)	BT50	PS-5
	Mynx 500	BT50	PS-5		VM 84	BT50	PS-5
	Mynx 650	BT50	PS-5		VM 925L	BT50	PS-5
	Mynx 750	BT50	PS-1		NX 5000	BT50	PS-5
	ACE-VM5410/510	BT40	PS-1		ACE-HC400/500	BT40	PS-1
	ACE-VM710	BT50	PS-5		ACE-HM500/630/800	BT50	PS-5
	ACE-VM900/950	BT50	PS-1		ACE-H100	BT50	PS-5
	ACE-V430	BT40	PS-1		ACE-HP4000/5100	BT40	PS-1
	ACE-VC500	BT40	PS-1		ACE-HP400	BT40	PS-1
	ACE-VMD450	BT40	PS-1		ACE-HP500/630	BT50	PS-5
	ACE-VMD600	BT40	PS-1				

PULL STUD BOLT

COMPARISON TABLE OF PULL STUD

MACHINE MANUFACTURER	PS / BOLT	PS / BOLT	PS / BOLT	MACHINE MANUFACTURER	PS / BOLT	PS / BOLT	PS / BOLT
WIA	VX380T/420T	BT30	PS-16	HWACHEON	SIRIUS-650/650N	BT50	PS-0
	MX380/420	BT30	PS-16		SIRIUS-850/850N	BT50	PS-0
	VX400/460	BT40	PS-1		SIRIUS-700	BT50	PS-0
	KV45/45P	BT40	PS-1		SIRIUS-12580	BT50	PS-0
	VX500	BT40	PS-1	S&T	TCH-45	BT40	PS-1
	VX510M/660M	BT40	PS-1		TCH-50	BT50	PS-6
	VX700/40	BT40	PS-1		TCH-80	BT50	PS-6
	VX700/50	BT50	PS-5		TCH-80TS	BT50	PS-6
	VX750	BT50	PS-5		FX-500H	BT40	PS-2
	VX500/50	BT50	PS-6		TNV-40A	BT40	PS-1
KV60N/90	BT50	PS-5	TNV-80A		BT40	PS-1	
SEMC	Any Mill LCV30A/B	BT30	PS-17	TNV-650V	BT50	PS-6	
	Any Mill LCV55S	BT50	PS-6	HASS	TM-1/2	BT40	PS-1
	Any Mill LCV650S	BT50	PS-5		VF-4SS/3SS/2SS	BT40	PS-1
	Any Mill ICV66	BT50	PS-5		VF-2TR	BT40	PS-1
	Any Mill ICV80	BT50	PS-5		VF-5/50TR	BT50	PS-5
	DMC-3000	BT50	PS-0		VF-9/50	BT50	PS-5
	PCH40	BT40	PS-1		VF-8/50	BT50	PS-5
	PCH50	BT50	PS-5		MAZAK		BT40
				BT50		PS-G41	
HWACHEON	SIRIUS-1	BT30	PS-16	MORI SEKI		BT40	PS-O8
	SIRIUS-550	BT40	PS-1			BT50	PS-51
	SIRIUS-UL/ULG	BT40	PS-1				
	SIRIUS-7040	BT50	PS-0				

MHP-100/HP-100

HEIGHT PRESETTER

· Magnetic Height Presetter

· Height Presetter

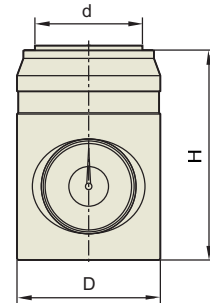
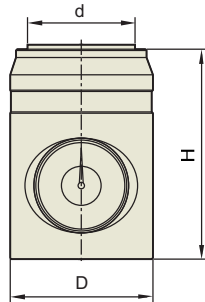

- * Both vertical and horizontal type usable
- * Slim design

- * Exclusively for vertical

CODE NO.	D	H	d	DIAL
MHP-100 (magnetic)	98	100	62	0.01
HP-100	68	100 * /- 0.01	62	0.01

3D TESTER

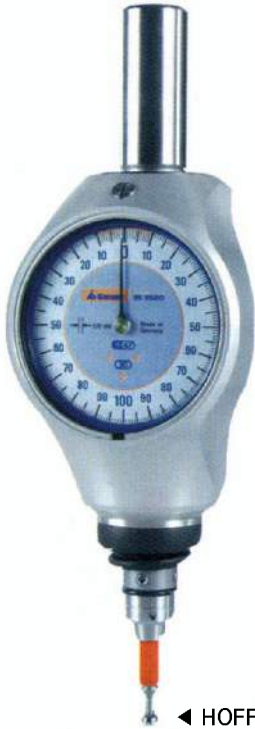

◀ HOFFMANN
(GERMANY)

1. Measurement of inner diameter and outer diameter in all 3 axes(X,Y,Z) with analogue values indicated by scale hand and quick zero setting. When measuring edge in all 3 axes(X,Y,Z) with scale hand indicating 12H, spindle axis is exactly situated at zero point of material to be cut. Calculation is not needed and there is no trial and error.
2. Wide common use : Such as functioning as calipers with single tool (Determining length, height, diameter and center)
3. Various use and quick exchange by 3 kinds of styluses : Special tool is not needed and screw doesn't need unfastening. So it is convenient and accurate plug-in fixed mechanism. (Readjustment is not needed when exchanging same styluses)
4. Max 0.01mm center is pre-adjusted before supplying.

TECHNICAL DETAILS

Display accuracy	Tolerance	0.01
Measuring accuracy	measured tolerance	0.01
Displacement travel x,y,z respectively	measurement range	7
Overall length (body and contact point)	Overall length	134
Display	Outer diameter size	50
Clamping shank	T8	16

ZERO MASTER



▲ HAIMER(GERMANY)

- ▶ QUICK ZERO SETTING FOR ALL MACHINES AND EDM
 - Easy to read and no detection error by special digital specifications
 - Measurement of inner and outer diameters in all 3 axes(X,Y,Z) and quick zero setting
 - Functioning as calipers with single tool (Determining length, height, diameter and center)
 - Reducing damage by 2 kinds of styluses with wide operation range
 - Reducing damage by 2 kinds of styluses with wide operation range

TECHNICAL DETAILS

ACCURACY	0.01mm
SIZE	30×13mm
NOTCH	0.01mm
CLAMPING SHANK	∅12
RANGE	100mm
BATTERY DURATION	3.00/hr

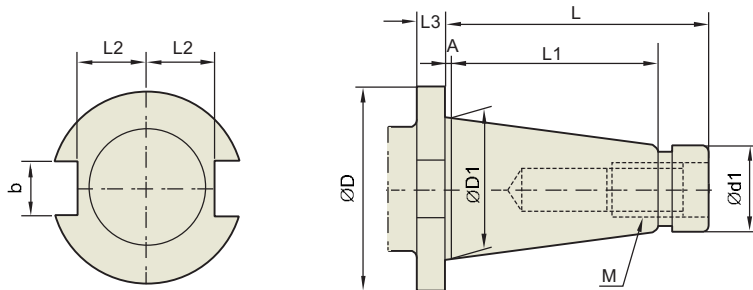
DIN 2080 - NT

TAPER No.	ØD	ØD1	ØD2	L	L1	L2	L3	A	b	M
NT30	46	31.75	17.4	68.4	48.4	16.2	10	1.6	16.1	1/2-13UNC
NT40	63	44.45	25.3	93.4	65.4	22.5	10	1.6	16.1	UNC 5/8-11
NT50	100	69.85	39.6	126.8	101.8	35.3	12	3.2	25.7	UNC 1-8
NT60	155	107.95	60.2	206.8	161.8	60	15	3.2	25.7	UNC 1,1/4-7

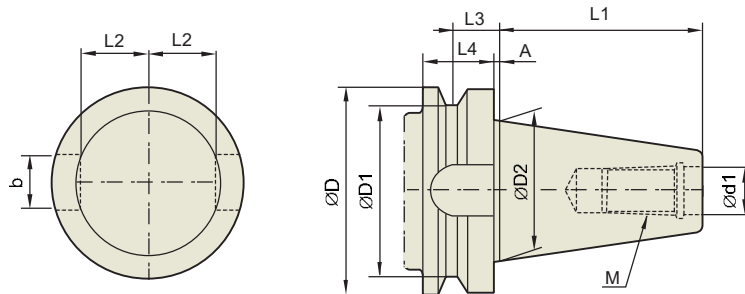
MAS 403-BT Bottle Grip Taper

TAPER No.	ØD	ØD1	ØD2	Ød1	L1	L2	L3	L4	A	b	M
BT30	46	31.75	38	12.5	48.4	16.3	13.6	20	2	16.1	M12×1.75
BT40	63	44.45	53	17	65.4	22.6	16.6	25	2	16.1	M16×2
BT50	100	69.85	85	25	101.8	35.4	23.2	35	3	25.7	M24×3
BT60	155	107.95	135	31	161.8	60.1	28.2	45	3	25.7	M30×3.5

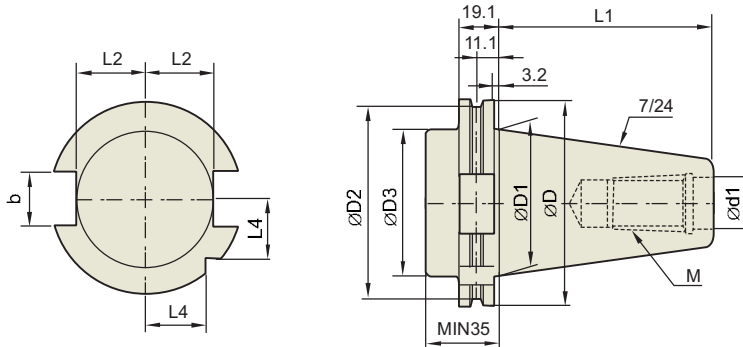
DIN 69871 - SK

TAPER No.	ØD	ØD1	ØD2	ØD3	Ød1	L1	L2	L3	L4	b	M
SK30	50	31.75	44.3	45	13	47.8	16.4	19	15	16.1	M12×1.75
SK40	63.55	44.45	56.25	50	17	68.4	22.8	25	18.5	16.1	M16×2.0
SK50	97.5	69.85	91.25	80	25	101.75	35.5	37.7	30	25.7	M24×3.0

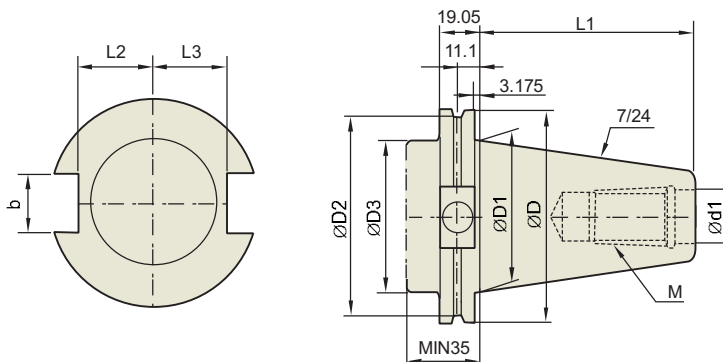
CAT SHANK ANSI B5.50 CH

TAPER No.	ØD	ØD1	ØD2	ØD3	Ød1	L1	L2	L3	b	M
CAT30	50	31.75	44.3	31.75	13	47.625	16.25	18.67	16.1	UNC1/2-13
CAT40	63.55	44.45	56.25	44.45	17	68.25	22.60	25	16.1	UNC5/8-11
CAT50	97.5	69.85	91.25	70.1	25	101.6	35.3	37.7	25.7	UNC1-18
CAT60	155	107.95	132.56	108	32	161.93	54	59.3	25.7	UNC1,1/4-7

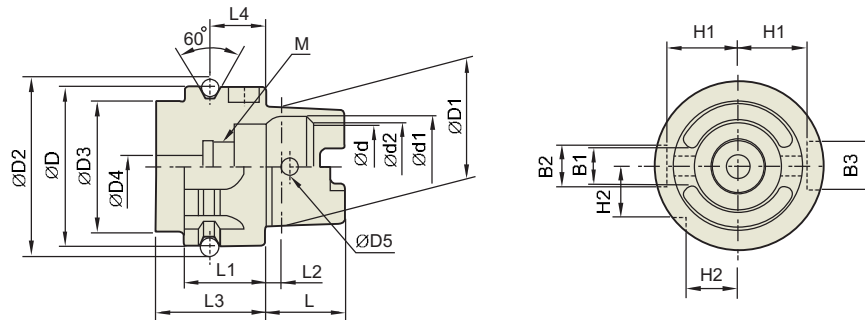
DIN69893 - HSK

TAPER No.	$\varnothing D$	$\varnothing D1$	$\varnothing D2$	$\varnothing D3$	$\varnothing D4$	$\varnothing D5$	L	L1	L2	L3	L4
HSK 40A	40	30	45.00	34	5.0	4.6	20	20	4.0	35	16
HSK 50A	50	38	59.30	42	6.8	6.0	25	26	5.0	42	18
HSK 63A	63	48	72.30	53	8.4	7.5	32	26	6.3	42	18
HSK100A	100	75	109.75	85	12.0	12.0	50	29	10.0	45	20

TAPER No.	$\varnothing d$	$\varnothing d1$	$\varnothing d2$	B1	B2	B3	H1	H2	M
HSK 40A	21	25.5	23	8.05	11	9	17.0	12.0	M12×1.0
HSK 50A	26	32.0	29	10.54	14	12	21.0	15.5	M16×1.0
HSK 63A	34	40.0	37	12.54	18	16	26.5	20.0	M18×1.0
HSK100A	53	63.0	58	20.02	22	20	44.0	31.5	M24×1.5

